

# EXHC-EXHD

## EXPLOSION-PROOF HOUSINGS

REVISION 1027



### MAIN FEATURES

Explosion-proof certified

Indoor and outdoor installations

Wide range of accessories

Weatherproof standard IP66

### DESCRIPTION

The EXH housings are made with strong Anticorodal aluminium die-cast alloy of AlSi Mg EN AB-42000 group. Depending on the model, all external components are stove enameled using powder or with special coatings offering an excellent resistance to UV rays, salt-spray, environment polluting substances (mod. 003R, mod. 005R). They are constructed according to the 94/9/CE ATEX standard and IEC 60079-0:2000, IEC 60079-1:2001, IEC 61241-0:2004, IEC 61241-1:2004 and GOST-R standard.

#### EXHC

The cylindrical body of EXHC housing (diameter 210mm and length 400mm) is closed on the opposite sides by two 12mm thick flanges. The housing is equipped with two 3/4" NPT IP66 ATEX cable glands that allow the wiring. The camera housing is equipped with an internal housing heater and optional sunshield.

#### EXHD

Explosion-proof housing with the same specifications as the EXHC series but fitted with a patented device for the protection of the glass which gives clear vision in dirty environments.

It consists of a connection flange with the housing, a closing flange and an explosion-proof central body containing a rugged transparent glass, a continuous current motor powered in 24Vac, two rollers and a transparent Mylar film, installed just in front of the glass. The motor drives, through four pinions with gear rim, the winding for recovering the dirty Mylar film, while at the same time the other winding installed on the opposite side releases the clean film.

*NOTE: the control unit of the glass protection device is not supplied with the EXHD.*

The transparent Mylar film, 80mm wide and 18m long, allows 350 steps. When the film is dirty, the operator will activate the motor shifting the film to obtain a clean camera picture (the step for allowing the complete shift of the dirty film is about 50mm). The end of the Mylar film will be indicated to the operator through marks printed on the last 50cm of the film.

#### EXWBJ

Bracket and swivel for EXH series in non-corrosive aluminium alloy (anticorodal). They allow the EXH housing to be firmly attached to the wall. Only the EXBJ allows the column mount.



EXHC + EXHS000



EXHD + EXHS001



EXBJ000



EXWBJ000



EXHC003R + EXWBJ00R

→ VERSION FOR THERMAL IMAGING CAMERAS AVAILABLE: EXHC000G □ 129

## EXHC-EXHD

AVAILABLE MODELS					
Code	Housing heater 24Vac	Housing heater 230Vac	Reinforced heater 24Vac	Glass protection device	Max consumption
EXHC000	•				20W
EXHC200		•			20W
EXHC003R			•		60W
EXHD001	•			•	22W
EXHD005R			•	•	62W

## TECHNICAL DATA

## GENERAL

Non-corrosive die-cast aluminium (anticorrosive)

Bicomponent polyurethane enamel with orange peel effect, RAL7032

Special painting for low temperature, blue colour RAL7001 (EXHC003R, EXHD005R, EXWB000R, EXBJ000R). Resistant to stress cracking, adverse weather conditions, detergents, salt-spray and typical airborne pollutants

Supplied with instruction manual and conformity declaration

## MECHANICAL

2 x Ex d 3/4" NPT IP66 cable glands ATEX according to the housing marking

External dimensions

EXHC Ø 210mmx427.5mm (8.2x16.8in)

EXHD Ø 250x573.5mm (9.8x22.6in)

Internal dimensions

EXHC Ø 180x380mm (7x14.9in)

EXHD Ø 180x460mm (7x 18.1in)

Internal usable area

EXHC 100x100x280mm (3.9x3.9x11in)

EXHD 100x100x280mm (3.9x3.9x11in)

Glass window

EXHC Ø 114mm (4.5in)

EXHD 70x56mm (2.7x2.2in)

Glass protection device

- Glass protection device Ø 250x140mm (9,8x5,5in)
- Mylar film 80mm (3.1in) wide and 18m (59ft) length, 350 shifting steps, marks printed on the last 50cm (19in)

Wall mount

- Load rating: 35kg (77lb)
- Length: 455mm (17.9in)

Parapet bracket

- Load rating: 35kg (77lb)

Glass protection device

- Glass protection device Ø 250x140mm (9,8x5,5in)
- Mylar film 80mm (3.1in) wide and 18m (59ft) length, 350 shifting steps, marks printed on the last 50cm (19in)

Wall mount

- Load rating: 35kg (77lb)
- Length: 455mm (17.9in)

Parapet bracket

- Load rating: 35kg (77lb)

## ELECTRICAL

Heater Ton 10°C±4°C (50°F±7°F) Toff 25°C±3°C (77°F±5°F)

- IN 24Vac, consumption 20W max
- IN 230Vac, consumption 20W max (only for EXHC200)

Reinforced heater Ton 10°C±4°C (50°F±7°F) Toff 25°C±3°C (77°F±5°F)

- IN 24Vac, consumption 20W max
- 3 resistors in the housing, consumption 60W max

Glass protection device

- 24Vac/Vdc, consumption 2W max

Devices to install inside the housing

- Camera equipped with lens with max total power of 20W
- Power supply max 24Vac or 230Vac
- Maximum specifications of the installable camera with lens: 100x100x280mm (3.9x3.9x11in)

## ENVIRONMENT

Indoor / Outdoor

Operating temperature with heater: -20°C / +50°C (-4°F / +122°F)

Operating temperature with reinforced heater: -40°C/+50°C (-40°F/+122°F)

*Always refer to the temperature in the marking.*

## CERTIFICATIONS



IECEx (TÜV Nord Certification), protocols IEC 60079-0:2000, IEC 60079-1:2001, IEC 61241-0:2004, IEC 61241-1:2004

- Ex d: explosion-proof housing for potentially explosive environments
- IIC: gas group
- T6: gas temperature classification
- Ex tD A21: dust ignition protection, for zone types 21-22
- IP66: IP protection degree
- T 85°C: maximum surface temperature for dusts

ATEX (TÜV Nord Certification), directive 94/9/CE

- II: group (surface device, no mining)
- 2: category (high protection degree, devices installed in zone 1 and 21 and in zone 2 and 22)
- GD: atmosphere type (gas and dusts)
- Ex d: explosion-proof housing for potentially explosive environments
- IIC: GAS group
- T6: GAS temperature classification
- tD A21: dust ignition protection for zones types 21-22
- IP66: IP protection degree
- T85°C: Maximum surface temperature for dusts

EXHC000 - EXHD001 - EXHC003R - EXHD005R

- IECEx Ex d IIC T6 Ex tD A21 IP66 T85°C
- ATEX  II 2 GD Exd IIC T6 tD A21 IP66 T85°C
-  0044: notify number from competent body
- GOST-R 1ExdIICT6 n DIP A21 T<sub>A</sub> T6
- UL certification pending

## ACCESSORIES

EXHS000 Sunshield 650mm (25,6in) for EXHC

EXHS001 Sunshield 760mm (29,9in) for EXHD

## BRACKETS AND ADAPTORS

EXWB000 Wall bracket and ball joint for EXH RAL7032

EXWB00R Wall bracket and ball joint for EXH RAL7001

EXBJ000 Ball joint for EXH RAL7032

EXBJ00R Ball joint for EXH RAL7001

**EXHC-EXHD**

**SPARE PARTS**

OCTEX3/4	Ex d 3/4" NPT IP66 ATEX cable gland for EXH
OEXGOM	Gaskets for cable glands Ex d 3/4" IP66 ATEX not armored
OEXVET	Front flange complete with glass for EXHC RAL7032
OEXDPV	Front flange complete with glass protection device for EXHD RAL7032
OEXMYLAR	Mylar film replacement kit, 18m (59ft) 350 steps
OSLIEX	Internal slide complete with heater for EXHC
OSLIEXD	Internal slide complete with heater for EXHD

EXHC

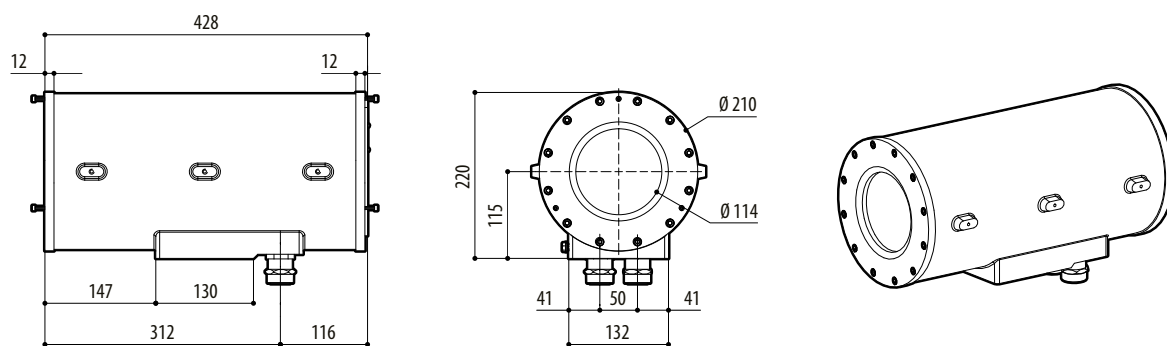

EXHD001

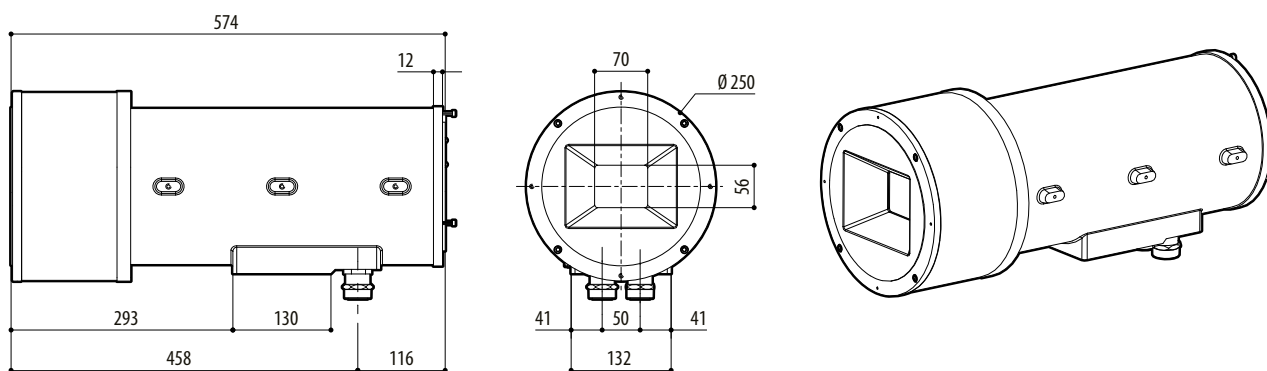

mm 1:10

PACKAGE							
Code	Unit weight		Package weight		Package dimensions (WxHxL)		Master carton unit
	kg	lb	kg	lb	cm	in	
EXHC	15.0	33.1	17.5	38.6	61.0x32.0x31.0	24.0x12.6x12.2	-
EXHD	24.0	52.9	26.5	58.4	43.0x67.0x67.0	16.9x26.3x26.3	-
EXWBJ	6.6	14.5	7.0	15.4	27.0x18.0x49.0	10.6x7.0x19.3	-
EXBJ	2.9	6.4	3.2	7.1	16.0x21.0x12.0	6.3x8.3x4.7	-

EXHC-EXHD

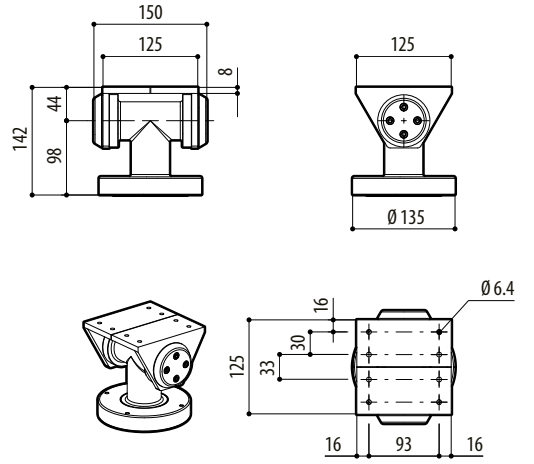

EXBJ

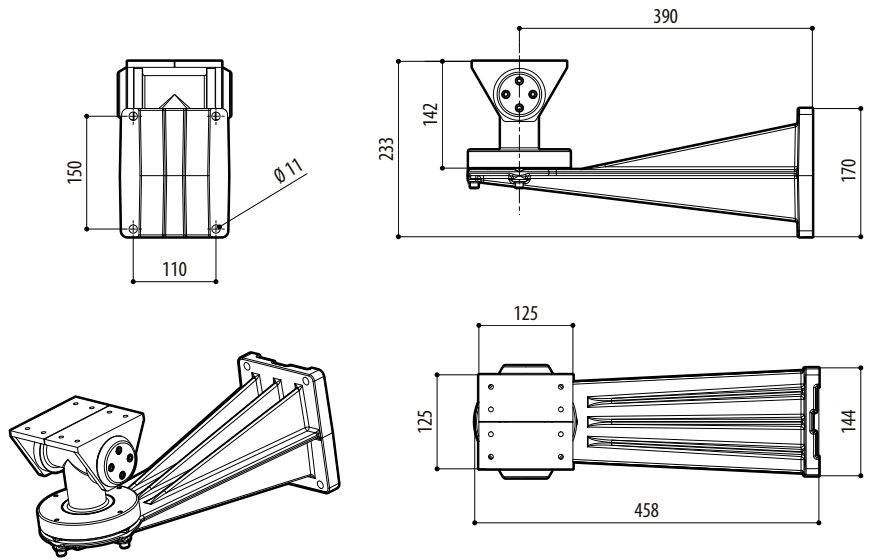

EXWBJ

mm 1:10