



PRODUCT SPECIFICATION

MODEL: V1600MM, V1505MM, V1520MM AND V1533MM

PRODUCT CODE: REFER TO TABLE 1

DESCRIPTION: HEAVY-DUTY MONITOR MOUNTS

- Models available for a variety of monitors
- Wall or ceiling mounting

The V1600MM, V1505MM, V1520MM and V1533MM Monitor Mounts provide secure, attractive mounting of closed-circuit television monitors. They are designed for use with VM5123, VM621, VM628, VM615, VM520 and VM6133 monitors. Refer to Table 1. These mounts can be incorporated into any decor. The monitor mounts may be mounted onto the wall, with the use of the V1501WM Wall Mount Adapter, or the ceiling, with the use of the V1502CA Ceiling Adapter.

**TABLE 1
MODELS, PRODUCT CODES AND COMPATABILITY**

Model Number	Product Code	Monitor Compatibility
V1600MM	6284	VM621, VM628, VM5123, VM5153
V1505MM	6285	VM615
V1520MM	6297	VM520
V1533MM	6299	VM6133

NOTES	SPEC NO.	REV.	SEC.
	984	799	7



V1600MM MONITOR MOUNT

ACCESSORIES AND OPTIONS

Model V1501WM Wall Mounting Adapter: Used for wall mounting of the monitor mounts. Weight: 7.1 lb (3.2 kg). Product code 2183.

Model V1502CA Ceiling Adapter: Must be used for ceiling mounting of the monitor mounts. Weight: 3.0 lb (1.4 kg). Product code 2184.

TECHNICAL INFORMATION

MECHANICAL

Mounting: Masonry: 5/16-inch lag screws, lock washers and lead anchors.
Wood: 5/16 × 2-1/2-inch lag screws and lock washers.
Steel: 5/16-inch machine screws, nuts and lock washers.

Monitor Size: 12 in. to 28 in. (305 mm to 710 mm).

Load Rating: 150 lb (68.0 kg).

CONTRACTORS' SPECIFICATION

HEAVY-DUTY MONITOR MOUNTS

The monitor mount shall be an adjustable unit, suitable for wall or ceiling mounting of monitors with screens measuring 12 to 28 in. (305 to 710 mm) diagonally. Dimensions shall not exceed: height, 26.5 in. (670 mm); width, 30.0 in. (760 mm). The load rating shall be 150 lb (68 kg). Construction shall be of steel and aluminum, and the unit weight shall not exceed 17.3 lb (7.8 kg).

The adjustable monitor mounts shall be Vicon model V1600MM (VM621, VM628, VM5123, VM5153), V1505MM (VM615), V1520MM (VM520) and V6133MM (VM6133). Wall mounting of the unit requires Vicon model V1501WM Wall Mounting Adapter. Suspended mounting requires Vicon model V1502CA Ceiling Mounting Adapter.

Product specifications subject to change without notice.
Copyright © 1999 Vicon Industries Inc. All rights reserved.

Vicon part number 8006-7984-00-00
Vicon and its logo are registered trademarks of Vicon Industries Inc.

Maximum Dimension: Height (H): 26.5 in. (670 mm).
 Width (W): 30 in. (760 mm).
 V1501WM/V1502CA: see Figure 1.

Shipping Dimensions: Monitor Mount (2 boxes)
 Height: 3.5 in. (89 mm).
 Width: 20.5 in. (521 mm).
 Depth: 22.0 in. (59 mm).

Height: 2.25 in. (57 mm).
 Width: 10.9 in. (277 mm).
 Depth: 6.25 in. (159 mm).

V1501WM
 Height: 6.3 in. (160 mm).
 Width: 16.0 in. (406 mm).
 Length: 18.25 in. (464 mm).

V1502CA
 Height: 3.75 in. (95 mm).
 Width: 5.0 in. (127 mm).
 Length: 5.3 in. (135 mm).

Shipping Weight: 19.5 lb (8.8 kg).
 V1501WM: 8.7 lb (3.9 kg).
 V1502CA: 3.2 lb (1.5 kg).

Shipping Volume: Monitor Mount (2 boxes)
 0.9 ft³ (0.025 m³).
 0.09 ft³ (0.0025 m³).
 V1501WM: 1.1 ft³ (0.03 m³).
 V1502CA: 0.06 ft³ (0.002 m³).

Weight: Approximately 17.3 lb (7.8 kg).

Construction: Aluminum and steel.

Finish: Dark gray enamel and black.

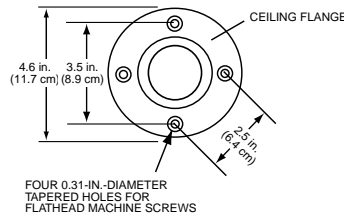
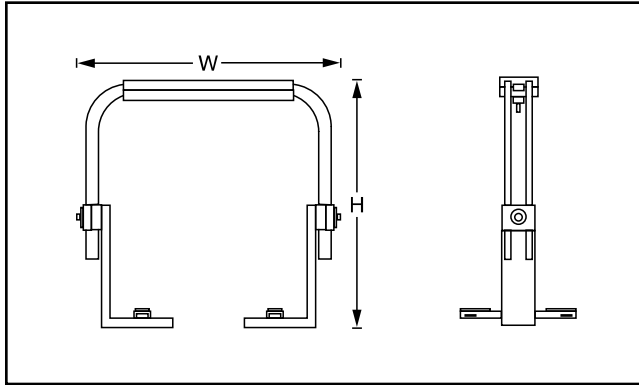

V1502CA CEILING MOUNTING ADAPTER

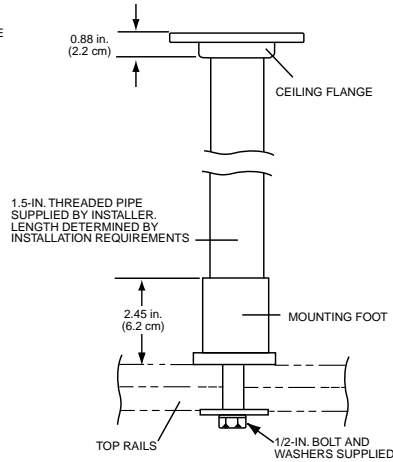

V1501WM WALL MOUNT ADAPTER

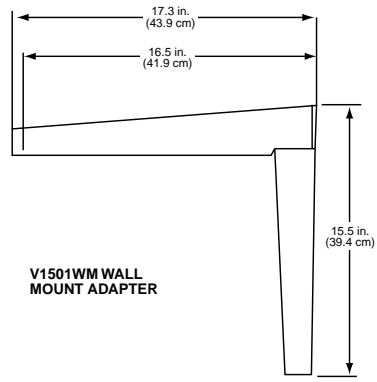
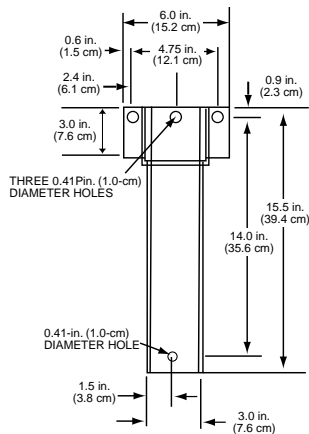

Figure 1
 V1502CA Ceiling Mounting Adapter and V1501WM Wall Mounting Adapter

