

General Description

The Super Connoisseur Camera Housing range provides a high quality, rigid, durable and effective enclosure for CCTV cameras for most applications.

All models in the range are suitable for exterior use with a weatherproof rating of IP66 (or BS EN 60529).

The HS range of Super Connoisseur is available in three size options;

- i.e. a short length housing with Sunshield.
- a medium length housing with Sunshield.
- an extended length housing with Sunshield,

The sunshield is adjustable along the length of housing body.

A de-mister/heater is fitted as standard.

Options of either an internal fan or combined internal / external cooling fans are also available.

Choices of models are available with an integral factory fitted wiper unit. State the operating voltage required at the time of ordering.

An adjustable mounting plate will suit most "camera with lens" assemblies.



Ease of access for serviceability and installation has been provided with the design of a hinged retained body. The RX range of Super Connoisseur (LONG) incorporates a built-in 10 function AC telemetry receiver (Molynx TRX228) with C type or D type telemetry interface and either 230V or 24V AC operation.

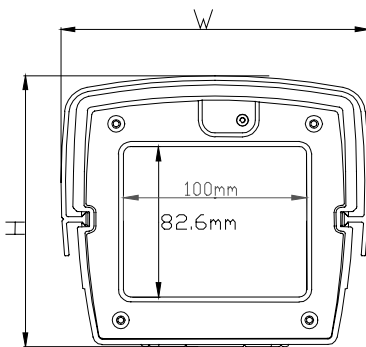

Model	External Dimensions.			Internal Dimensions. (no fan)		
	L	W	H	L	W	H
Short	491mm	155mm	148mm	264 mm	125 mm	100mm
Medium	577mm	155mm	148mm	350 mm	125 mm	100mm
Long	627mm	155mm	148mm	400 mm	125 mm	100mm
Weight: (incl. sunshield)			Useable Height with wiper fitted		88mm	
4.5kg (short)	5.5kg (medium)	6kg (long)	(Sunshield: 1.1kg)			
Sunshield: Length						
424mm	510mm	560mm.	Width with sunshield: 168mm			

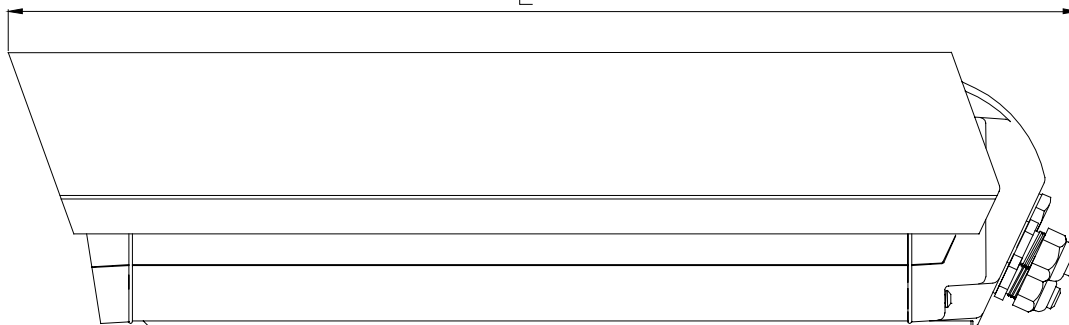

Mounting Details

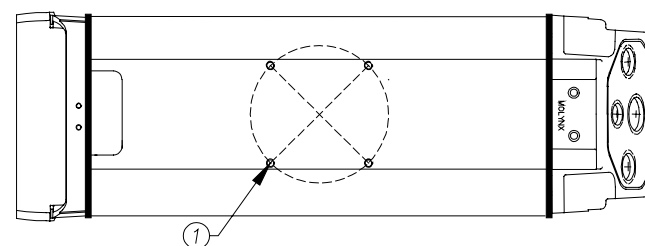

View of camera housing base with mounting holes

Key:

1) 4 x M6 mounting holes on a 101.6 mm pitch circle diameter (4" PCD). Recommended maximum thread engagement into the base plate = 10.5mm.

Whilst every effort has been made to ensure that all information is correct at the time of publication, Molynx reserve the right to alter specifications without prior notice

Silvermines plc Group of companies. Registered in England No. 1100742.

Albany Street, Newport, S. Wales, NP9 5XW

Tel: +44 (0)1633 821000. Fax: +44 (0)1633 850893.

Email: sales@silvermines.com

Technical Specifications

PARAMETERS	TYPICAL / MIN. / MAX.
External Fan Option: (Width and Height dimensions remain the same as for standard models)	Length: (non-adjustable extended Sunshield) HS07 (Short) 586 mm, HS09 (Long) 722 mm
Material:	Aluminium extrusion (Housing body / Sunshield) Glass filled polyester thermoset (front & rear end caps)
Finish:	Housing Body : Polyester powder coat, (RAL7032) grey Sunshield : Polyester powder coat, White gloss
Electrical	
Supply Voltage Options:	230/110v AC @ 50/60 Hz, 24/12v AC/DC (non wiper, non fan).
Fuse rating:	2 Amps @ 230/110v AC, 5 Amps @ 24v AC/DC.
Cable Entry:	1 x 25mm removable threaded plug to accept conduit. 1 x Cable Gland - 16mm 2 x Cable Glands - 20mm
Cable Range:	Cable Range - 5mm to 10mm diameter. Cable Range - 6mm to 12mm diameter.
Heater:	7 watts nominal, 25 watts max. PTC resistor heating element
Electrical Connection:	Mains supply connections via fused pcb mounted terminal blocks. Use crimp ferrules when terminating cables.
Cooling Fan Specifications : Operating Voltage: Current Consumption:	24v AC @ 50/60Hz (<i>only</i>). Internal Fan : 180mA (4.32W) External Fan : 130mA (3W)
Environmental	
Operating Temperature:	-20°C to +60°C (maximum typical ambient operating temperature of Camera and Lens. Ta = 40°C)
Relative Humidity:	Up to 95% non condensing
Weatherproof Rating:	IP66, BS EN 60 529
Suitable Equipment	
Suitable Wiper: All wiper options are factory fitted and must be requested at the time of ordering.	Wiper unit motor supply variants are either W1 ~ AC 230v, W2 ~ AC 110v or, W3 ~ AC 24v.
Suitable Washer: (state the pump voltage required)	WA01 ~ 5 litre capacity, WA02 ~ 25 litre capacity.
Suitable Brackets :	Preset ~ BK03 ~WBH10 (for short housing only), BK04 ~WBH20, (BK07 ~WBH40) Fixed ~ BK07 ~WBP40 (use with P/T unit), BK14 ~WBP100 equivalent (used with external fan option, HS09)
Suitable Pan/Tilt :	Molynx ~ MUSTANG12 range AC/DC (OTT or side-mount), MUSTANG 15 DC continuous rotation (OTT mount). Videmech ~ 550 SERIES, 600 SERIES, 650 SERIES.
Suitable Telemetry Receiver :	TRX228 (10 func. AC) internal/external fitting, RX range . TRX250 (17 func. AC), TRX260 (17 func. DC) external. Videmech ~ 152 external receiver(17 func. AC), 150 external receiver (17 func. DC).

Whilst every effort has been made to ensure that all information is correct at the time of publication, Molynx reserve the right to alter specifications without prior notice

Silvermines plc Group of companies. Registered in England No. 1100742.

Albany Street, Newport, S. Wales, NP9 5XW. Email: sales@silvermines.com

General enquiries; Tel: +44 (0)1633 821000. Fax: +44 (0)1633 850893.

Technical information Lo-cost line: 0845 6031 299. U.K. Free Fax service: 0808 1000 606.

TS016-1

