

CHSL4010/4011

Protective Camera Housing

VANDERBILT



The multi-purpose protective camera housing in Vanderbilt design is made of aluminium and equipped with a sunshield and integrated heater. The housing can accommodate all current Vanderbilt cameras with fixed focus, varifocal or zoom lenses.

The protective housing can either be fixedly installed using one of the available wall brackets or mounted on a pan-and-tilt head. The housing cover is easy to remove, facilitating on-site installation and cabling of the camera with lens.

Key features include:

- Washer/wiper unit available as an option
- Integrated heater to prevent condensation on the front window
- Protection rating IP66 for outdoor use
- Vanderbilt corporate design

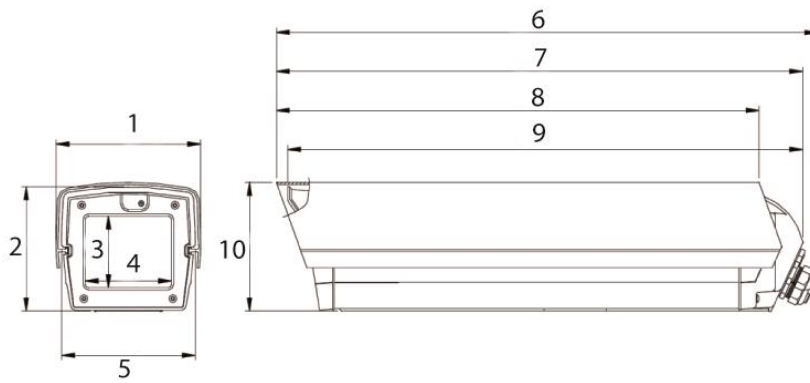

1	168 mm	6	627 mm
2	143 mm	7	609 mm
3	82.5 mm	8	559 mm
4	100 mm	9	596 mm
5	155 mm	10	149 mm

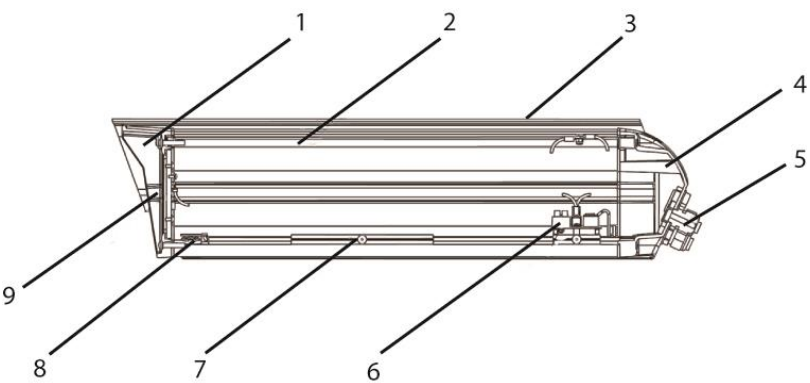

1	Front end cap	6	Terminal board
2	Housing body	7	Camera mounting plate
3	Sunshield	8	Demister assembly
4	Rear end cap	9	Window
5	Cable glands		

Technical data

	CHSL4010	CHSL4011
Nominal voltage	110 – 230 V AC, 50/60 Hz	12 – 24 V AC, 50/60 Hz
Fuse rating (fuse F1)	2 A, 250 V AC, 5x 20 type (T), HBC	5 A, 250 V AC, 5x 20 type (T), HBC
Electrical connections	Main supply connections via fused PCB-mounted terminal blocks. Use crimped ferrules when terminating cables. 6-way pillar terminal block available for user connections.	
Cable entry	1x M25 (fitted with blanking plug) 1x M16 (5 – 10 mm diameter cable range) 2x M20 (6 – 12 mm diameter cable range)	
Heater	Nominal: 7 W Max.: 25 W PTC resistor heating element, thermostatically controlled	

Environmental	
Operating temperature	-20 to +60 °C (-20 to +40 °C when wiper kit fitted) Ensure fitted equipment has suitable temperature range for the application (e.g. max. typical ambient operating temperature of camera and lens; Ta = 40 °C)
Max. internal dissipated power	50 W (25 W (incl. wiper motor) when wiper kit fitted)
Relative humidity	Max. 95 % (non-condensing)
Protection rating	IP66, BS EN 60 529
Material	Toughened glass window Housing body/sunshield: Aluminium extrusions Front and rear end caps: Die-cast aluminium
Finish	Housing body: Polyester powder coat, RAL9006 White Aluminium Sunshield: Polyester powder coat, RAL9006 White Aluminium End caps: Polyester powder coat, RAL7016 Grey
Internal dimensions (W x H x D)	125 x 100 x 400 mm
Usable height with wiper fitted	88 mm
Weight	Excluding sunshield: 4.9 kg Including sunshield: 6.0 kg
Suitable pan-and-tilt units	CDD2425, CDD2416-T, CDAP2316-T, CDAP2416-T
Suitable brackets	CHBS2815, CDBC0075, CAHA1040, CDBS4540

Note:

When using lenses with a focal length < 3 mm in conjunction with 1/3" cameras, parts of the camera housing may be visible in the video image (this is due to its design).

Details for ordering

Type	Part no.	Designation	Weight
CHSL4010	V54561-C603-A1	Camera housing, 400 mm, 230 V AC	4.9 kg
CHSL4011	V54561-C603-A2	Camera housing, 400 mm, 24 V AC	4.9 kg
CDD2425	V54561-C700	Pan-and-tilt head, side mount model, 24 V DC	8.0 kg
CDD2416-T	V54561-C701	Pan-and-tilt head, over-the-top model, 24 V DC	8.0 kg
CDAP2316-T	V54561-C702	Pan-and-tilt head, over-the-top model, 230 V AC	8.0 kg
CDAP2416-T	V54561-C703	Pan-and-tilt head, over-the-top model, 24 V AC	8.0 kg
CAHL4010-WU	V54561-C607-A1	Washer unit 230 V AC, 50 Hz	2.0 kg
CAHL4011-WU	V54561-C607-A2	Washer unit 24 V AC, 50 Hz	2.0 kg
CAHL4010-WK	V54561-C608-A1	Wiper kit 230 V AC	0.8 kg
CAHL4011-WK	V54561-C608-A2	Wiper kit 24 V AC	0.8 kg
CAHL401x-W	V54561-B604	Spare wiper arm	0.1 kg
CHBS2815	V54561-C605	Wall swivel bracket	0.6 kg
CDBC0075	V54561-C710	Corner bracket	4.5 kg
CDBS4540	V54561-C704	Fixed bracket	2.0 kg
CDBS6699	V54561-C705	Heavy-duty bracket	8.0 kg
CAHA1040	V54561-C609	Swivel mount	0.7 kg
CADC1599	V54561-C706	Column spacer 152 mm (6")	2.0 kg
CADC3099	V54561-C707	Column spacer 304 mm (12")	3.0 kg
CAPD1210-C230	V54561-B7-A1	Power supply unit 230 V AC / 12 V DC, 500 mA	0.5 kg