

2/3 Format Motorized Zoom (Auto-Iris)

C14ZME(C31009)

C-MOUNT
Unit:mm

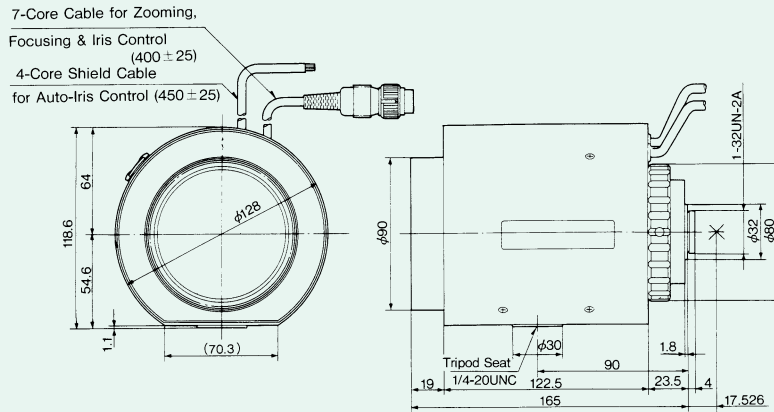

Specification

Focal Length	10~140mm	
Max. Aperture Ratio	1:1.9	
Iris Range	F1.9~720	
Operation Method	Iris	Auto
	Focus	Motorized
	Zoom	Motorized
1/4 Format Angle of View	Horizontal	19.89~1.52
	Vertical	14.95~1.14
1/3 Format Angle of View	Horizontal	26.41~2.02
	Vertical	19.89~1.52
1/2 Format Angle of View	Horizontal	34.96~2.68
	Vertical	26.41~2.02
Min. Object Distance	2.8m	
Back Focal Length	20.35mm	
Flange Back Length	17.526mm	
Filter Size	φ 86.0mm P=1.0mm	
Applicable Temp. Range	-10°C~+50°C	
Dimensions	128×118.6×165mm	
Weight	2000g	
Metering Method	Continuously Adj.	
Supply Vol. & Current	DC8~15V Max. 35mA	
Input Signal	VS or V Signal	
Iris Accuracy	±20% at V Signal Level	
Sensitivity Adj.	0.5~1.0Vp at V Signal Level	
Input Impedance	High Impedance	
Response Speed	Approx. 1.5 sec.	
Remarks	Video Iris	

		Focus	Zoom
Control Voltage & Current	Type1	DC6V Max. 120mA / Motor	DC6V Max. 120mA / Motor
	Type2	DC±12V Max. 65mA / Motor	DC±12V Max. 65mA / Motor
	Type3	DC±6V Max. 120mA / Motor	DC±6V Max. 120mA / Motor
	Type5	DC12V Max. 65mA / Motor	DC12V Max. 65mA / Motor
	Operation Speed	Type1	Approx. 9 sec.
Type2		Approx. 9 sec.	Approx. 9.5 sec.
Type3		Approx. 9 sec.	Approx. 9.5 sec.
Type5		Approx. 9 sec.	Approx. 9.5 sec.

1 Format Motorized Zoom (Auto-Iris)

B12ZCME(C21517)

C-MOUNT
Unit:mm

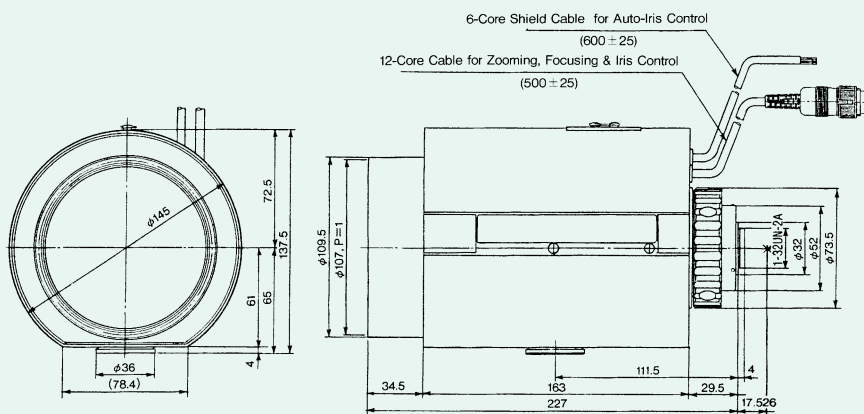

Specification

Focal Length	15~180mm	
Max. Aperture Ratio	1:1.9	
Iris Range	F1.9~1400	
Operation Method	Iris	Auto
	Focus	Motorized
	Zoom	Motorized
1/4 Format Angle of View	Horizontal	13.29~1.18
	Vertical	9.97~0.89
1/3 Format Angle of View	Horizontal	17.69~1.57
	Vertical	13.29~1.18
1/2 Format Angle of View	Horizontal	23.54~2.09
	Vertical	17.69~1.57
Min. Object Distance	2.8m	
Back Focal Length	32.19mm	
Flange Back Length	17.526mm	
Filter Size	φ 107mm P=1.0mm	
Applicable Temp. Range	-10°C~+50°C	
Dimensions	145×137.5×227mm	
Weight	3070g	
Metering Method	Continuously Adj.	
Supply Vol. & Current	DC8~15V Max. 50mA	
Input Signal	VS or V Signal	
Iris Accuracy	±20% at V Signal Level	
Sensitivity Adj.	0.5~1.0Vp at V Signal Level	
Input Impedance	High Impedance	
Response Speed	Approx. 1.5 sec.	
Remarks	Video Iris	

		Focus	Zoom
Control Voltage & Current	Type1	DC6V Max. 140mA / Motor	DC6V Max. 140mA / Motor
	Type2	DC±12V Max. 80mA / Motor	DC±12V Max. 80mA / Motor
	Type3	DC±6V Max. 140mA / Motor	DC±6V Max. 140mA / Motor
	Type5	DC12V Max. 80mA / Motor	DC12V Max. 80mA / Motor
	Operation Speed	Type1	Approx. 8.5 sec.
Type2		Approx. 8.5 sec.	Approx. 8.0 sec.
Type3		Approx. 8.5 sec.	Approx. 8.0 sec.
Type5		Approx. 8.5 sec.	Approx. 8.0 sec.