



EH2500 Series Enclosure

OUTDOOR, RAIN- AND DUSTPROOF

Product Features

- Designed for Maximum Rain Protection
- Dustproof
- Compact, Lightweight
- Aluminum Construction
- Meets NEMA Type 4 and IP66 Standards
- Accepts Cameras with Fixed Focal Length or Motorized Zoom Lenses
- Optional Accessories Include Sun Shroud and Dual-Element Heater/Defroster



EH2500 SERIES



ENCLOSURE WITH SUN SHROUD

The enclosures of the **EH2500 Series** are rain- and dustproof to protect CCTV cameras from adverse environmental conditions.

Constructed from aluminum, the enclosures are compact and lightweight. They can be installed on fixed mounts or pan/tilt units.

The **EH2500 Series** can accommodate a variety of cameras with fixed focal length or motorized zoom lenses. The enclosures have an outside diameter of 4.25 inches (10.80 cm) and are available in three lengths: 8 inches (20.32 cm), 12 inches (30.48 cm), and 15 inches (38.10 cm).

Each model features a sled for camera mounting and a T-handle on the rear plate to assist in removing the plate during installation and servicing.

Optional accessories include a sun shroud. The heater has two elements so that it can operate as a heater and defroster. When the temperature drops below 70°F (21°C), one element turns on for defogging. When the temperature falls below 40°F (4°C), the second element turns on for defrosting.

Cable entry is through two adjustable cable glands located conveniently on the rear plate.

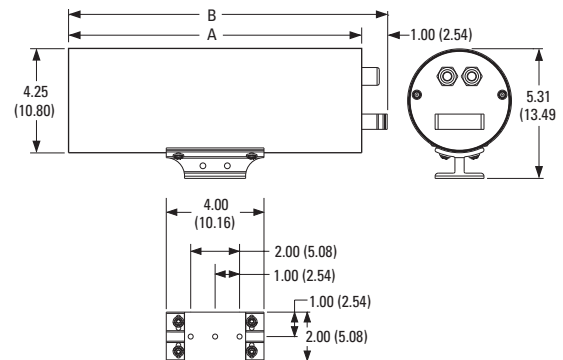

	A	B
EH2508	8.00 (20.32)	9.00 (22.86)
EH2512	12.00 (30.48)	13.00 (33.02)
EH2515	15.00 (38.10)	16.00 (40.64)

NOTE: VALUES IN PARENTHESES ARE CENTIMETERS; ALL OTHERS ARE INCHES.



DataFAX
SPEC: 21473
MANUAL: 214736

C1473 / REVISED 10-02

IP66



International Organization
for Standardization;
Registered ISO 9001



TECHNICAL SPECIFICATIONS

MODELS

Model Number	Basic Enclosure	120 VAC	24 VAC	230 VAC	Heater	Defroster	Blower	Max. Power Consumption
EH2508	•							
EH2508-1		•			•	•		15W
EH2508-2			•		•	•		15W
EH2508-3				•	•	•		15W
EH2512	•							
EH2512-1		•			•	•		15W
EH2512-2			•		•	•		15W
EH2512-3				•	•	•		15W
EH2515	•							
EH2515-1		•			•	•		15W
EH2515-2			•		•	•		15W
EH2515-3				•	•	•		15W

MECHANICAL

Camera Mounting	Multiple mounting holes on removable camera sled
Latching	Two captivated screws
Maximum Camera/Lens Size	Accepts camera and lens combinations* (including BNC connector) up to:
EH2508	6.25" L x 2.75" W x 2.75" H (15.88 x 6.99 x 6.99 cm)
EH2508-1/-2/-3	5.25" L x 2.75" W x 2.75" H (13.34 x 6.99 x 6.99 cm)
EH2512	10.25" L x 2.75" W x 2.75" H (26.04 x 6.99 x 6.99 cm)
EH2512-1/-2/-3	9.25" L x 2.75" W x 2.75" H (23.50 x 6.99 x 6.99 cm)
EH2515	13.25" L x 2.75" W x 2.75" H (33.66 x 6.99 x 6.99 cm)
EH2515-1/-2/-3	12.25" L x 2.75" W x 2.75" H (31.12 x 6.99 x 6.99 cm)
Viewing Window	0.375" (0.95 cm) thick Lexan®
Viewing Window Area	
Basic models	3.25" (8.25 cm) diameter
-1/-2/-3 models	2.50" (6.35 cm) diameter
Cable Entry	Two adjustable 1/2-NPT liquid-tight glands

*Assumes lens is fully extended.

ELECTRICAL

Input Voltage	120, 24, or 230 VAC for heater
Connector	4-position terminal block
Heater	120 VAC, 24 VAC, 230 VAC; 15 W Dual-element heater is thermostatically controlled. Defroster; activates on at 70°F (21°C), off at 85°F (29°C) Heater; activates on at 40°F (4°C), off at 67°F (19°C)

GENERAL

Construction	Aluminum	
Finish	Gray polyester powder coat	
Environment	Indoor/outdoor -50° to 122°F (-46° to 50°C)	
Weight	Unit	Shipping
EH2508	2.95 lb (1.34 kg)	5.0 lb (2.27 kg)
EH2508-1/-2/-3	3.10 lb (1.41 kg)	5.0 lb (2.27 kg)
EH2512	3.75 lb (1.70 kg)	6.0 lb (2.72 kg)
EH2512-1/-2/-3	3.90 lb (1.77 kg)	6.0 lb (2.72 kg)
EH2515	4.63 lb (2.10 kg)	7.0 lb (3.18 kg)
EH2515-1/-2/-3	4.83 lb (2.19 kg)	7.0 lb (3.18 kg)

OPTIONAL ACCESSORIES

EH25/8104ORKIT	O-ring service/repair kit; includes two O-rings, one tube O-ring lubrication, and two desiccant bags
SS2508	Sun shroud for EH2508 series; reduces internal temperature approximately 10-15°F (6-10°C)
SS2512	Sun shroud for EH2512 series
SS2515	Sun shroud for EH2515 series

CERTIFICATIONS/RATINGS

- CE, Class B (all except 120 VAC models)
- Meets NEMA Type 4 standards
- Meets IP66 standards

RECOMMENDED MOUNTS

Ceiling/Pedestal	EM1009U,	Medium duty ceiling/pedestal mount; maximum load 40 lb (18.12 kg)
	EM1015U	
	EM3000*	Ceiling J-mount; maximum load 20 lb (9.07 kg)
Wall	EM1450	Light duty wall mount; maximum load 20 lb (9.07 kg)
	EM2400*	Light duty wall mount; maximum load 20 lb (9.07 kg)
Pipe/Pole	EM1109	Medium duty pedestal mount for horizontal or vertical pipe/pole applications; maximum load 40 lb (18.12 kg)
	EM2000	Medium duty mount for vertical pipe/pole applications; maximum load 40 lb (18.12 kg)
	EM2200	Medium duty mount for horizontal pipe/pole applications; maximum load 40 lb (18.12 kg)

*These mounts are recommended for **indoor** use only.



Pelco Worldwide Headquarters:

3500 Pelco Way, Clovis, California 93612-5699 USA

USA & Canada Tel: (800) 289-9100 • FAX (800) 289-9150 • DataFAX (800) 289-9108

International Tel: (559) 292-1981 • FAX (559) 348-1120 • DataFAX (559) 292-0435

www.pelco.com

Lexan® is a registered trademark of the General Electric Company. Specifications subject to change without notice. ©Copyright 2002, Pelco. All rights reserved.