

# External Wedge Camera

Vandal resistant external day/night camera



## OVERVIEW

A vandal resistant camera with an IP67 weatherproof rating, low profile, and flexible mounting options, the MobileView™ Wedge Camera is ideally suited for exterior transit vehicle applications.

The camera has a varifocal lens and delivers 520 TVL of exceptional picture quality. The camera has built-in visible light sensors to monitor ambient light and initiate IR illumination when needed in low-light applications and ICR to block IR interference to the sensor during the day. An optional heater allows operations in cold weather environments.

## STANDARD FEATURES

- 1/3" Sony Super HAD CCD
- Resolution: 520 TVL
- Streamlined wedge type chassis
- Varifocal lens
- IR illuminators provide clear images up to 50 feet away
- Visible light sensor provides IR illumination only when needed
- ICR allows IR to the sensor only when needed
- Rugged, vandal resistant and tamper resistant
- IP67 housing
- Simple mounting without a bracket
- Optional built-in heater

# External Wedge Camera

Vandal resistant external day/night camera

North America  
T 855-286-8889

Asia  
T 852-2907-8108

Australia  
T 61-3-9239-1200

Europe  
T 32-2-725-11-20

Latin America  
T 561-998-6114

## Specifications

### Video

Sensor	1/3" SONY Super HAD CCD
Lens Type	Varifocal Lens: f=2.9-10mm/F=1.2
Lens Movement	Fixed
Total Pixels	NTSC: 768x494/PAL: 752x582
Effective Pixels	NTSC: 768x494/PAL: 752x582
Horizontal Resolution	520 TVL
Sync. Mode	Sync. Mode Internal sync
S/N Ratio	Over 48dB (AGC Off)
Electronic Shutter	1/50 (1/60)~1/100,000
Sensitivity	0.4 Lux / F=1.2 (IR OFF) ; 0 Lux (IR ON)
Day/Night	Auto IR Cut Removable
Day/Night Detection	Visible light sensor
Back Light Comp.	Yes
Auto Gain Control	Yes
Auto White Balance	Yes (2500K~9000K)
Gamma Correction	0.45
Video Format	NTSC/PAL
Scanning	NTSC: 525TVL, 60 fields/sec PAL: 625TVL, 50 fields/sec
Video Output	BNC 1.0Vp-p , 75ohm

### Electrical

Power Source	DC 12V
Power Consumption	.84W no IR; 2W with IR
Current	70mA no IR; 165mA with IR

### General

Weight	0.12 lbs. (60 gms)
Dimensions (L x W x H)	2.76 x 1.97 x 0.87 in. (70 x 50 x 22 mm)

## Ordering Information

<b>MSS-7008-VS</b>	MobileView™ IR Wedge Camera, 520 TVL, f2.9-10mm, 12VDC, Streetside
<b>MSS-7008-VC</b>	MobileView IR Wedge Camera, 520 TVL, f2.9-10mm, 12VDC, Curbside
<b>MSS-7008-VHS</b>	MobileView IR Wedge Camera, 520 TVL, f2.9-10mm, Heater, 12VDC, Streetside
<b>MSS-7008-VHC</b>	MobileView IR Wedge Camera, 520 TVL, f2.9-10mm, Heater, 12VDC, Curbside

## Dimensional Diagrams

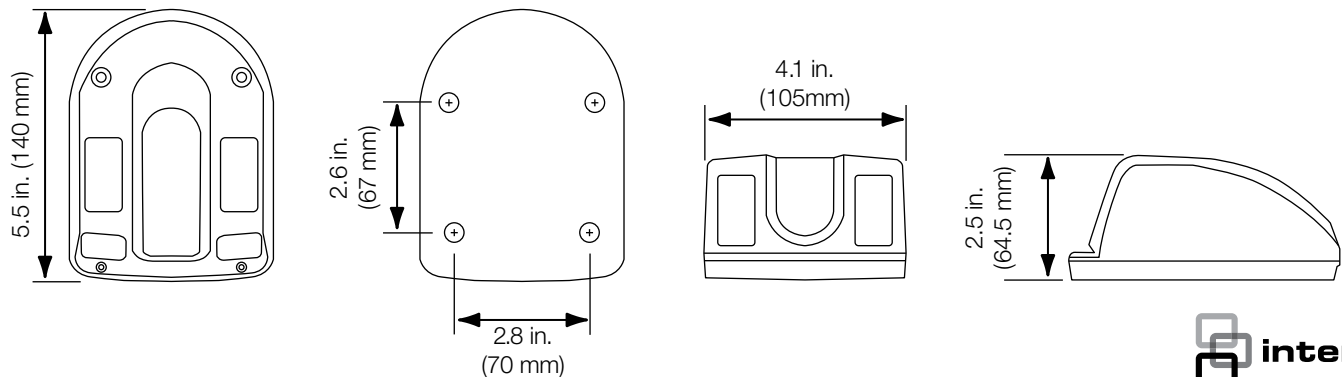

interlogix.com

Specifications subject to change without notice.



© 2012 Interlogix.  
All rights reserved.  
Interlogix is part of UTC Climate, Controls & Security,  
a unit of United Technologies Corporation.

210-3587 2012/11 (71365E)