

HHC12 Series

MEDIUM ENVIRONMENTAL HOUSING

The new HHC12 Series line of environmental housings are stylish and functional camera enclosures, with a design focus of simplifying installations.

The new side entry design of the HHC12 and the hinged mounting tray allows total access to all sides of the camera. A camera and lens can be installed, adjusted, and tested without shifting the position of the housing. After the camera is set up, the lid can be closed and secured with no effect to the camera setup.

The HHC12 housing incorporates a flexible-mounting track, allowing it to fit any mount regardless of the distance between the mounting holes. Optional features include a sunshield, and a factory installed heater and blower.

The HHC12 housing is constructed of die-cast and extruded aluminum with a two-tone gray epoxy powder coating, making it attractive, durable, as well as corrosion resistant. IP66 weather and dust proofing is accomplished with durable neoprene gaskets making the housing suitable for all indoor and outdoor applications. HHC12 housings can accommodate 1/2" and 1/3" cameras with fixed and Vari-focal lenses.

Market Opportunities

The Honeywell HHC12 Series of environmental camera housings are designed for applications where ease of installation and setup of the camera system is a primary concern. The attractive design, rugged construction and range of mounting options to walls, ceilings and poles makes these housings suitable for a wide range of indoor and outdoor applications including: parking lots, lobbies, building entranceways, atriums, driveways, loading docks and foyers.

Features

- Die-cast and extruded aluminum construction
- Total access design allows easy access to camera from all sides
- Integrated "Flex mount" adjustable mounting track
- 3/4", 1/2" and 1/4" cable entry glands (PG21, PG16, and PG9)
- Sunshield option
- Indoor and outdoor installations
- Epoxy powder coated for corrosion resistance
- Dust-proof, IP66 weatherproof rating
- Pre-assembled heater and blower models available
- Dual positive locking clamps
- Reversible camera mounting tray to elevate low profile cameras



HHC1200



HHC12WM
HHC12WM2

SPECIFICATIONS

Mechanical	
Max Camera Size (W x H x L)	HHC1200/HHC12WM 3.1" x 3.2" x 11.4" (78 mm x 82 mm x 290 mm)
	HHC12WM2 3.1" x 3.2" x 9" (78 mm x 82 mm x 230 mm)
Camera Mounting	Reversible slotted camera
Weight	4.2 lb (1.90 kg)
Viewing Window	Clear 1/8" double density glass
Window Size (W x H)	2.9" x 2.4" (73 x 61 mm)
Cable Entry	3 glands, PG9, PG16, PG21
Dimensions	See drawings
Construction	Extruded and die-cast aluminum
Finish	Gray, two tone, epoxy powder coating
Environmental Rating	IP66
Operating Temp	-20°C to 60°C
	-4°F to 140°F
Heater Specifications HHC12WM2	
Power Supply	24 VAC, 20 W
Heater On	t < 5°C +/-3°
	t < 41°F +/-5°
Heater Off	t > 15°C +/-3°
	t > 59°F +/-5°
Blower Specifications HHC12WM2	
Power Supply	24 VAC, 3.4 W
Blower On	t > 35°C +/-3°
	t > 95°F +/-5°
Blower Off	t < 20°C +/-3°
	t < 68°F +/-5°

Recommended Mounts and Adapters	
HHMC21J	Ceiling "J" mount, 21"H, 30 lb (13.5 kg) max, internal cable channel, Gray
HHMW13	Wall mount, 13"L, 30 lb (13.5 kg) max, internal cable channel, Gray
HHMPMA	Pole Mount Adapter for the HHMW13 wall mount
HHMCA	Corner Mount Adapter for the HHMW13 wall mount

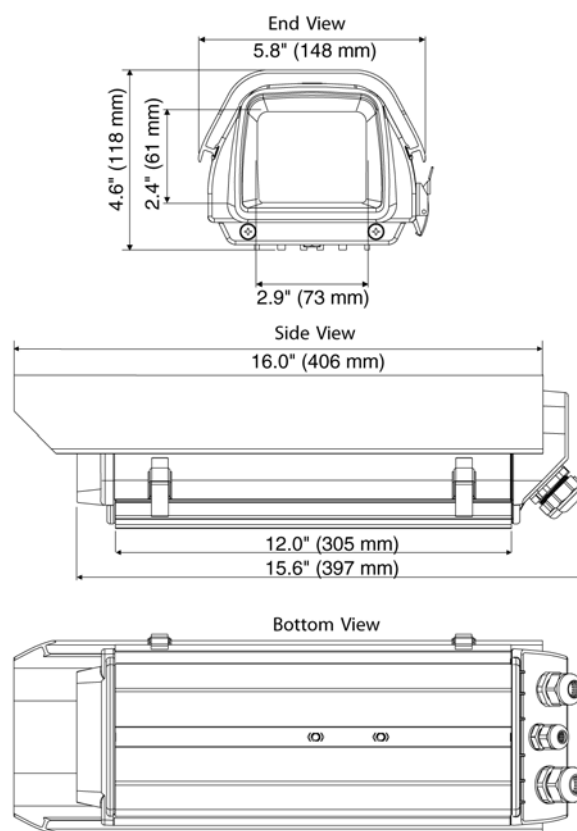

Ordering	
HHC1200	Enclosure, 15" front to rear length, side access, indoor/outdoor for 1/2" or 1/3" CCTV cameras with fixed and Vari-focal length lenses
HHC12WM	HHC1200 housing with HHMW13 wall mount
HHC12WM2	HHC1200 housing with 24 VAC heater, blower and HHMW13 wall mount

NOTE: Honeywell reserves the right, without notification, to make changes in product design or specifications.

Honeywell Security

Honeywell Video Systems
 2700 Blankenbaker Pkwy, Suite 150
 Louisville, KY 40299
 1.800.796.CCTV
 www.honeywell.com

HV05280
 L/HHC12HSG/D
 January 2006
 ©2006 Honeywell International Inc.

