

HB72SX

SUPER HIGH RESOLUTION DAY/NIGHT BULLET CAMERA WITH INFRARED ILLUMINATORS

Our Performance camera range includes indoor, outdoor and low light cameras, high performing IR bullet cameras and mini-domes that are competitively priced, easy to install and even easier to use. These cameras offer sharper image quality so you see every detail when it counts.

The HB72SX IR bullet-style camera comes standard with IR illumination, making it perfect for 24/7 surveillance. When the ambient light drops below a user-defined threshold, the IR LEDs activate and the camera changes automatically from colour to black and white, capturing perfect colour pictures by day and clear black and white images at night.

The 4.3 mm lens offers a wide field of view to complement the 12 IR LEDs that can illuminate up to 15 metres, depending on scene reflectance. The 530 TVL sensor provides clean, crisp images in day and night conditions.

The HB72SX camera installs easily and quickly. It comes standard with a two-conductor pigtail that connects to the barrel connector so there is no need to cut wires during installation. The mounting bracket installs quickly and securely with three screws on walls or ceilings, indoors or out.

Market Opportunities

The HB72SX is a cost effective surveillance solution for applications that experience changing light conditions throughout the day and require extra illumination at night. The HB72SX offers a simple yet solid design that provides optimum performance for both indoor and outdoor applications including lobbies, atriums, vestibules, gated entrances, foyers, loading docks and driveways.

Features

- Discreet, bullet-style camera with 12 IR LEDs
- Weatherproof housing with IP 65 rating
- 4.3 mm lens
- Super high resolution colour: 530 TVL - 1/3" Sony Super HAD CCD
- IR LED visible range of 15m
- Easy to install mounting bracket reduces installation time
- Two-conductor pigtail is standard for connection to barrel connector
- Equalisation valve prevents vacuum effect caused by sudden changes in barometric pressure



HB72SX

SPECIFICATIONS

Operational	
Video Standard	PAL
Scanning System	625/50 lines (PAL)
Image Sensor	1/3" Sony HAD CCD sensor
Number of Pixels (H x V)	HB72X: 795x596 (PAL)
Minimum Illumination	0.3 lux day/0 lux night, operates in complete darkness
Horizontal Resolution	530 TVL
Video Output	1.0 Vp-p @ 75 Ohms
Sync System	Internal
S/N Ratio	50 dB or more (AGC off)
Auto Gain Control	Off/On
Automatic Electronic Shutter	1/50–1/100,000 sec (PAL)
Lens Type	4.3 mm
Horizontal Field of View	58.5°
White Balance	Auto
Gamma	0.45
IR LEDs	850 nm, 12 LEDs
IR Illumination Distance	15m
Electrical	
Input Voltage	12 VDC
Input Range	10 VDC – 15 VDC
Power Consumption	3.6 W (max) with IR LEDs on
Mechanical	
Dimensions	See Diagrams
Weight	1.3 lb (0.6 kg)
Construction	Finish: Brushed and anodised aluminium with sunshield
Colour	HB72SX – Silver
Connector	Main Video Output: BNC connector Power Input: 10 VDC - 15 VDC

Environmental	
Temperature	Operating: 14°F to 113°F (-10°C to 45°C) Storage: -4°F to 149°F (-20°C to 65°C)
Rating	IP65
Regulatory	
Emissions	FCC CE: EN 55022 Class A
Immunity	CE: EN 50130-4
Safety	EU: EN 60065
Accessories	
Power Supplies	
PSU-PER12VDC-UK	12VDC, UK Plug

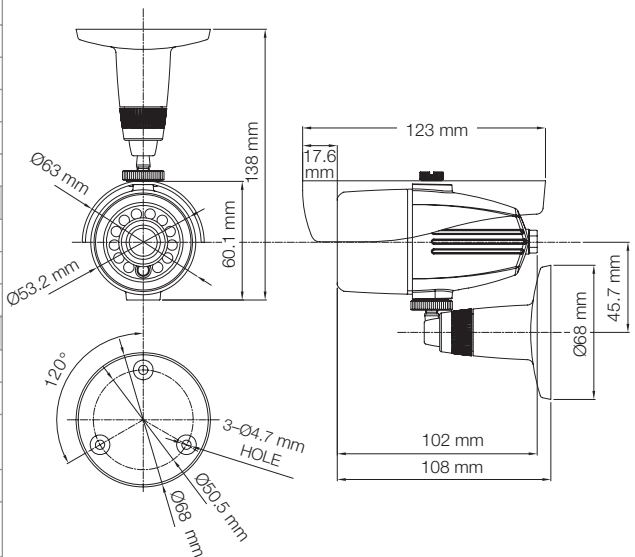

Ordering	
HB72SX	1/3" CCD Super High Resolution IR Bullet Camera, 530 TVL, 4.3 mm, 12 IR LED, Silver, PAL

NOTE: Honeywell reserves the right, without notification, to make changes in product design or specifications.

Honeywell Security & Data Collection

Honeywell Systems Group
Aston Fields Road
Whitehouse Industrial Estate
Runcorn
Cheshire
WA7 3DL
Tel: 08448 000 235
Fax: 01928 701 063
www.honeywell.com/security/uk

HVS-HB72SX-UK-01(0209)DS-GCSC
February 2009
© 2009 Honeywell International Inc.

Honeywell