

# MHD, MHC, CM5

CEILING & PEDESTAL ENCLOSURE MOUNTS



MHD



CM5



MHC

The MHD, MHC and CM5 series mounts are stylish and functionally designed "J" ceiling and pedestal enclosure mounts with features such as an integrated adjustable platform that allows easy position adjustment of Ultrak® environmental enclosures.

The two ceiling mounts are constructed of curved aluminum tube with an epoxy powder coating that make them corrosion resistant.

All of these heavy-duty ceiling and pedestal mounts can support loads of at least 30 lbs.

- Aluminum construction
- Epoxy powder coated for corrosion resistance
- Integrated friction-controlled adjustable platform
- Versital and affordable



# MHD, MHC, CM5

## TECHNICAL SPECIFICATIONS

### MODELS

<b>CM5</b>	Medium-duty "J" ceiling mount for HEM & HEG series Ultrak® enclosures or other enclosures with 2 3/4" hole pattern. Comes with integrated adjustable platform
<b>MHC21SHG</b>	Ceiling "J" mount, enclosure, 23" H, 30 lbs (13.5kg) max, Ultrak® grey
<b>MHD10SHG</b>	Pedestal mount, enclosure, 10" H, 55 lbs (25kg) max load, Ultrak® grey

### MECHANICAL

Pan Adjust	360°
Tilt	70° MHC21 (90°)
Enclosure Mounting:	
CM5	HEX bolts (hardware provided)
HD510	HEX bolts (hardware provided)
MHC21	HEX bolts (hardware provided)
Maximum Load:	
CM5	40 lbs (18kg)
MHD10	55 lbs (25kg)
MHC21	30 lbs (13.5kg)
Dimensions	See drawings
Construction:	
CM5	Aluminum tube
MHD10	Aluminum tube
MHC21	Steel, aluminum mounting plate
Weight:	
CM5	3.5 lbs (1.6kg)
MHD10	1.0 lbs (.45kg)
MHC21	4.3 lbs (1.95kg)

### GENERAL

Finish	Almond color, epoxy powder coating
Environment	Indoor/outdoor

### RECOMMENDED ENCLOSURES

<b>CM5</b>	HEM12 series, HEG14 series
<b>MHD10</b>	HEM12 series, HEG14 series, KHTM12
<b>MHC21</b>	HEM12 series, HEG14 series, KHTM12

### MHC21

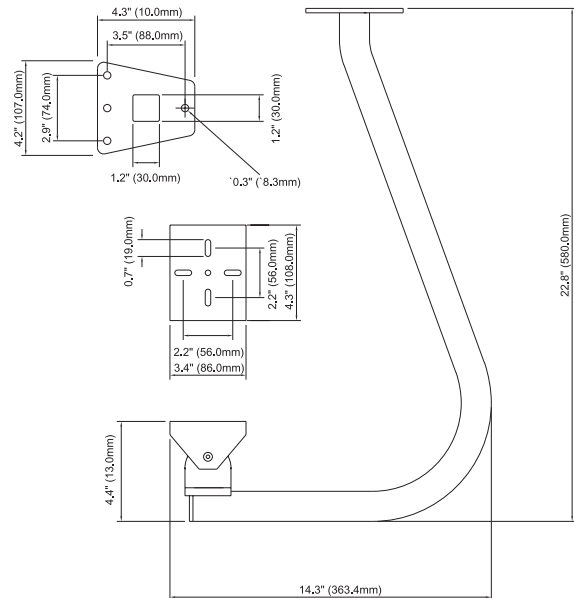

### CM5

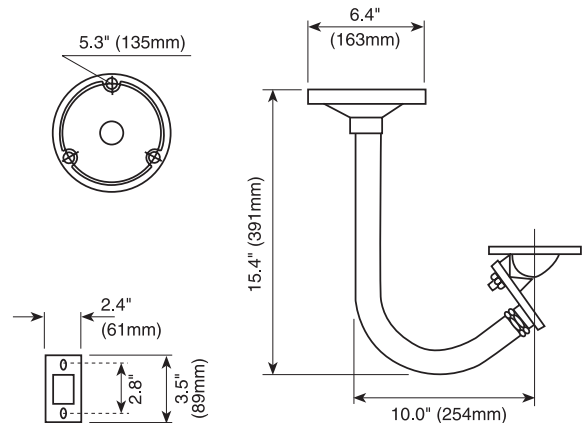

### MHD10

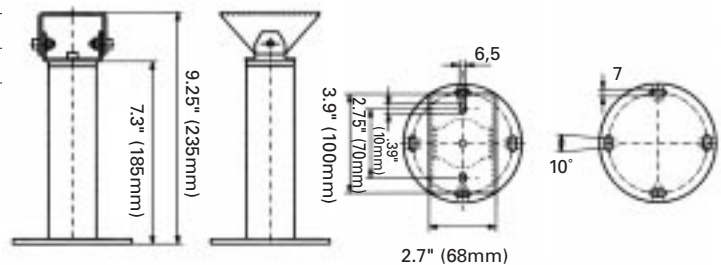

Design and specifications subject to change without notice.

Conversion: 1" = 25.4mm  
Measurement conversions are approximate

#### Ultrak Worldwide Support Center:

1301 Waters Ridge Drive  
Lewisville, TX 75057  
(800) 796-2288 (972) 353-6500  
Fax (972) 353-6670

