

High Definition & High Performance



42", 32" TFT-LCD Color Monitor

STM-42L/32L



- 1,366 x 768@60Hz resolution
- 1,100 : 1 High contrast ratio (STM-42L), 3,000 : 1 High contrast ratio (STM-32L)
- 500cd/m² High brightness
- 5ms Response time (STM-42L), 8ms Response time (STM-32L)
- 2 BNC inputs / outputs, S-Video with loop-through, VGA input
- LCD Protection Glass
- 3D Comb Filter
- Built-in Speakers

42", 32" TFT-LCD Color Monitor

STM-42L/32L

Specifications

		STM-42L	STM-32L
Display	Screen Size	42"	32"
	Pixel Type	Active Matrix TFT	
	Max. Resolution	1366 x 768@75Hz	
	Pixel Pitch	0.227 x 0.681mm	0.17 x 0.51mm
	Brightness	500cd/m ²	
	Contrast Ratio	1100 : 1	3000 : 1
	Aspect Ratio	16 : 9	
	Viewing Angle (H/V)	178°/178°	
	Display Color	16.7 Million	
	Response Time	5ms	8ms
Audio	Video System	NTSC / PAL	
	Frequency(H)	45 ~ 50 KHz	45 ~ 52KHz
	Frequency(V)	47 ~ 63 KHz	48 ~ 66KHz
	Built in Speakers	7W x 2	2W x 2
Interface	Video In / Out	(BNC Type) 2 / 2	
	S-Video In / Out	(Y/C, Loop-Through Out) 1	
	RGB In	(15Pin D-Sub) 1	
	DVI In	1	
	HDMI	1	
	Trigger	1	
	Audio In / Out	(RCA Type) 2	
Controller	PC Stereo In	1	
	Transmitter Remote Control	Yes	
Features	PIP (Picture in Picture)	Yes	
	PBP (Picture by Picture)	Yes	
	Filter Type	3D Comfilter / DeInterlace	
	LCD Protection Glass	Yes	
	Rack Mountable Kit	Optional	
Dimensions	Multi-lingual Language	English, Spanish, French, German, Italian, Portuguese, Dutch	
	VESA™ DDC Compatible	Yes	
	Outline Dimension (With Stand)	1063 x 730 x 304mm (41.85" x 28.74" x 11.99")	792 x 488.5 x 226.6mm (28.82" x 19.23" x 8.92")
Cabinet Mounts	Outline Dimension (Without Stand)	1063 x 655 x 120mm (41.85" x 27.89" x 4.72")	792 x 543.3 x 103.5mm (28.82" x 20.42" x 4.07")
	Net Weight	31Kg (68.3lbs)	22.6Kg (49.8lbs)
	Weight	35Kg (77.2lbs)	24.6Kg (54.2lbs)
Electrical	Cabinet Finish / Tilt Stand	Black / Yes	
	Mounts Size	130 x 130 x 634mm (BS M4 x 10mm Screw)	200 x 200mm (BS M6 x 16mm Screw)
	Regulation	TUV NRTL (=UL), CB, FCC (A), CE-Emc (LVD)	
	Consumption	Max. 42W	Max. 36W
	Electrical Ratings	AC100 ~ 240V (50/60Hz)	
	Operating Temperature	0 ~ 40°C	

Dimensions

Unit : mm (inch)

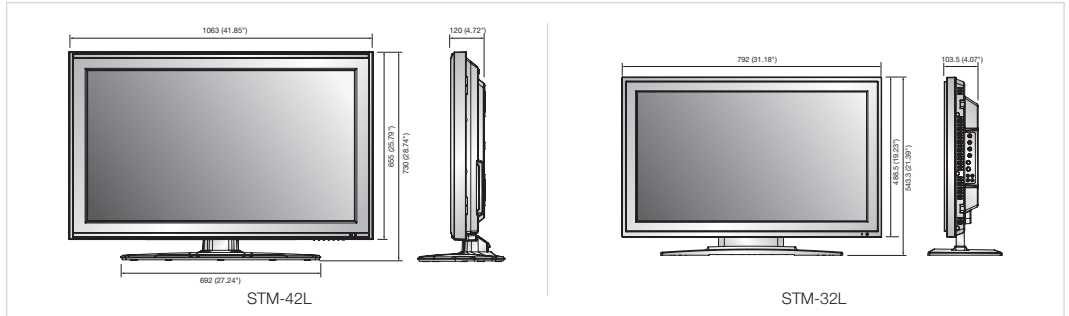

Connector



Design and specifications are subject to change without notice.



The Eco mark represents Samsung Techwin's will to create environment-friendly products, and indicates that the product satisfies the EU RoHS Directive.



SAMSUNG TECHWIN CO., LTD.

145-3, Sangdaewon 1-dong, Jungwon-gu, Seongnam-si, Gyeonggi-do Korea 462-703
Tel : +82-31-740-8151~8 Fax : +82-31-740-8145
www.samsungcctv.com

SAMSUNG TECHWIN AMERICA INC.
1480 Charles Willard St, Carson, CA 90746, UNITED STATES
Tel Free : +1-877-213-1222 Fax : +1-310-632-2195
www.samsungcctvusa.com

SAMSUNG TECHWIN EUROPE CO., LTD.
Samsung House, 1000 Hillwood Drive, Hillwood Business Park
Chertsey, Surrey, UNITED KINGDOM KT16 0PS
Tel : +44-1932-45-5300 Fax : +44-1932-45-5325

TIANJIN SAMSUNG TECHWIN OPTO-ELECTRONICS CO., LTD.
No.11 Wei 6 Street, Micro-Electronic Industrial Park
Jingang Road, Tianjin, P.R. CHINA 300385
Tel : +86-22-23887788 Fax : +86-22-23887788

■ DISTRIBUTED BY

