

*CCTV Lenses  
for Surveillance*

# DAY/NIGHT MEGAPIXEL 32x SURVEILLANCE ZOOM LENS

**DN**

10 – 320 mm F2.5

**D32x10R4D**



## DAY / NIGHT

Offers 24 / 7 Surveillance Capabilities

## Mega Pixel

Sharper, High Quality Images

## Compact Size

Fits easily into all applications

## Iris Remote

Auto Iris is remotely operable, allowing light intensity to be fine tuned.

## Multi Power (6V, ±6V, 12V, ±12V)

Multi power compatibility for use with existing control systems.

Designed for day and night operation, the D32x10R4D is the Mega Pixel Zoom lens for this application. Specialized optics provide crisp color images in daylight and black and white images in darkness - without the need to refocus.

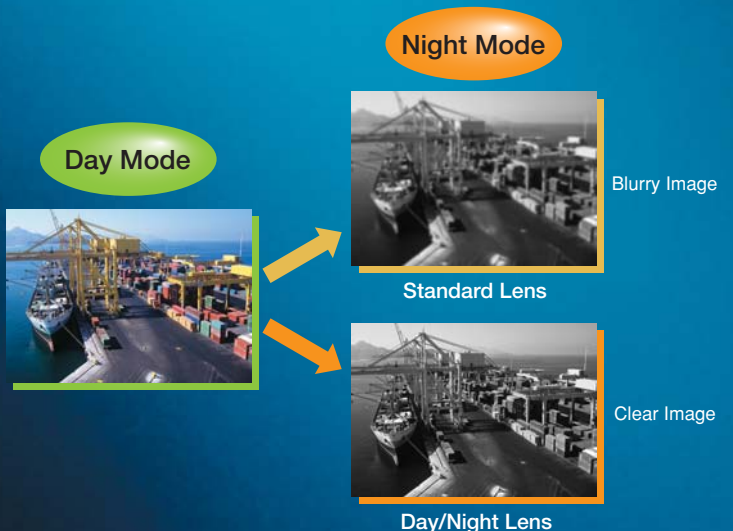

ISO14001

ISO9001

# DAY/NIGHT

## 32x SURVEILLANCE ZOOM LENS

32x



D32x10R4D-V41



- ZOOM**  
Zoom
- WIDE**  
Wide Angle
- TELE**  
Telephoto Long Focal
- MOTOR DRIVE**  
Motor Drive
- Day~Night**  
Day & Night
- 1.5 Mega**  
For Megapixel Camera
- VIDEO**  
Video Auto Iris
- IRIS-REMOTE**  
Iris Remote
- C-mt**  
C Mount
- METAL**  
Metal Mount
- PRESET**  
Potentiometer
- N D**  
ND Filter

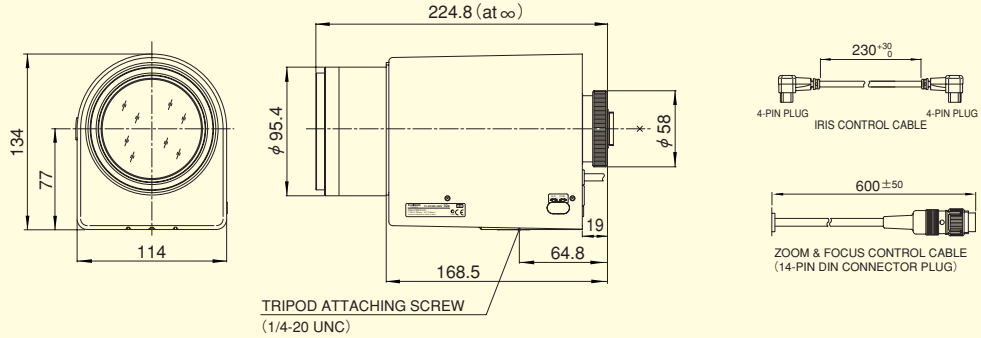

Unit : mm

Focal Length (mm)		10~320 (32x)	
Iris Range		F2.5 ~ T1500 (Equivalent to F1500)	
Operation	Zoom	Motor Drive	
	Focus	Motor Drive	
	Iris	Auto (Video Type) or Remote	
Angle Of View (H×V)	1/2"	WIDE	35°29' × 26°59'
		TELE	1°09' × 0°52'
	1/3"	WIDE	26°59' × 20°24'
		TELE	0°52' × 0°39'
	1/4"	WIDE	20°24' × 15°23'
		TELE	0°39' × 0°29'
Focusing Range (From Front Of The Lens) (m)		∞ ~ 3	
Object Dimensions at M.O.D. (H×V) (mm)	1/2"	WIDE	1746 × 1310
		TELE	57 × 43
	1/3"	WIDE	1310 × 982
		TELE	43 × 32
1/4"	WIDE	982 × 737	
	TELE	32 × 24	
Back Focal Distance (in air) (mm)		22.70	
Exit Pupil Position (From Image Plane) (mm)		-53	
Filter Thread (mm)		M82 × 0.75	
Mount		C	
Mass (kg)		2.5	
Standard Accessories		Iris Control Cable Connection Connector (14-pin)	
Remarks		With Metal Mount	

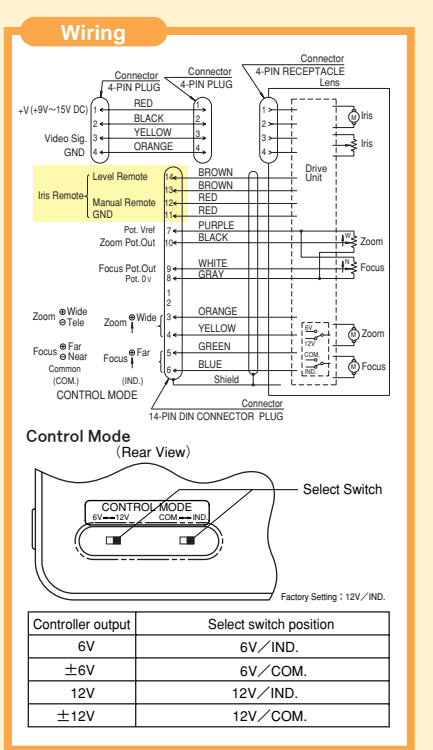

### FUJINON FUJIFILM

www.fujinoncctv.com

**Japan / Northeast Asia**  
**FUJINON CORPORATION**  
 1-324 Uetake, Kita-ku, Saitama City,  
 Saitama 331-9624, Japan  
 TEL.+81-48-668-2152 FAX.+81-48-651-8517  
 E-mail: sales@msv.fujinon.co.jp  
 URL http://www.fujinon.co.jp/

**North & South America**  
**FUJINON INC.**  
 10 High Point Drive, Wayne,  
 NJ 07470-7434, U.S.A.  
 TEL.+1-973-633-5600 FAX.+1-973-633-5216  
 E-mail: lens.sales@fujinon.com  
 URL http://www.fujinon.com/

**Europe / Africa / Middle East**  
**FUJINON (EUROPE) GmbH**  
 Halskestrasse 4, 47877 Willich,  
 Germany  
 TEL.+49-2154-924-0 FAX.+49-2154-924-290  
 E-mail: fujinon@fujinon.de  
 URL http://www.fujinon.de/

**Southeast Asia / West Asia**  
**FUJINON SINGAPORE PTE. LTD.**  
 BLK211 Henderson Road, #10-04,  
 Henderson Industrial Park, Singapore 159552  
 TEL.+65-6276-4988 FAX.+65-6276-6911  
 E-mail: fujinon@fujinon.com.sg  
 URL http://www.fujinon.com.sg/

**China**  
**FUJINON HONG KONG LTD.**  
 Unit 2605-2607, Level 26, Metroplaza,  
 Tower 1, 223 Hing Fong Road,  
 Kwai Fong N.T., Hong Kong  
 TEL.+852-2311-1228 FAX.+852-2724-1118  
 E-mail: enquiry@fujinon.com.hk  
 URL http://www.fujinon.com.cn/

**Oceania**  
**FUJINON AUSTRALIA PTY. LTD.**  
 Unit-18, 52 Holker Street, Silverwater,  
 N.S.W. 2128, Australia  
 TEL.+61-2-9748-2744 FAX.+61-2-9748-2428  
 E-mail: sales@fujinon.com.au