



## Pan & Tilt Units (Series VPT-40/41/42)

FDP-No.: 73218

### VPT-40/24VAP

- 20 kg Load Capacity
- Supply Voltage: 24 VAC
- 50/60 Hz Operation
- Backlash: <math><0,2^\circ</math>
- High Torques
- Hardened Gears
- Rugged Housing
- No Maintenance Required
- Protection Rating: IP 66
- Autopan Function as Standard



---

### Specifications:

---

Load capacity	20 kg
Nominal voltage range	24 VAC (+20% to -10%)
Current consumption/motor (at 50 Hz)	285 mA
Speed at nominal voltage	6°/sec. horizontal, 3°/sec. vertical (at 60 Hz: +20%)
Max. torque at nominal speed	16.5 Nm horizontal / 33 Nm vertical (Running torques at 50 Hz)
Rotation range	360° horizontal, +/-90° vertical
Backlash	<math><0.2^\circ</math>
Limit switch control	Internally adjustable (Micro switchers)
Plug connection	7-pin socket
Potentiometers on both axes	No
Autopan function	Standard (24 VAC)
Protection rating	IP 66
Mounting	Upright or inverted
Housing	Aluminium frame with plastic covers
Colour	C31 anodized / RAL 7032
Temperature range	-40°C to +70°C
Dimensions (HxWxD)	See drawing
Weight	6.5 kg
Parts supplied	Screw set, 7-pin connector, Allen wrench key (4 mm)

Accessories	
EDP No. / Type	Description
77488 VPT/IRB-4L	L-bracket for one LED infra-red illuminator 15W/30W/60W, suitable for VPT-40/41/42
77489 VPT/IRB-4T	T-bracket for two LED infra-red illuminators 15W/30W/60W, suitable for VPT-40/41/42
73008 WD-2N	Wall bracket for pan & tilt heads, recommended for VPT-40/41/42, light grey finish (RAL 7032)

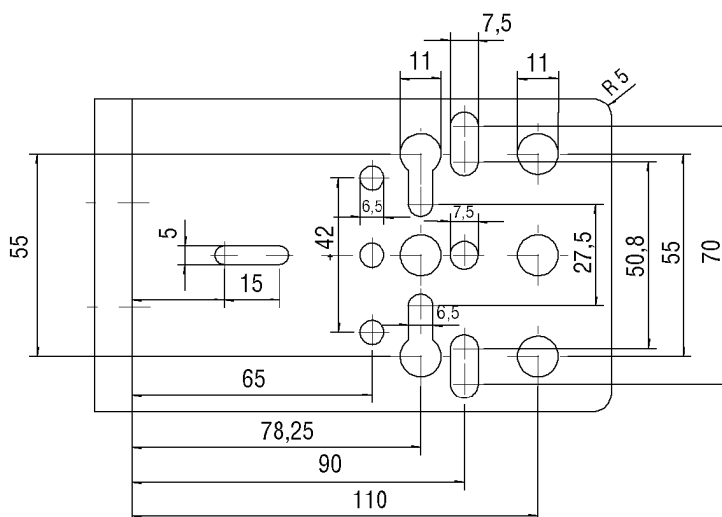
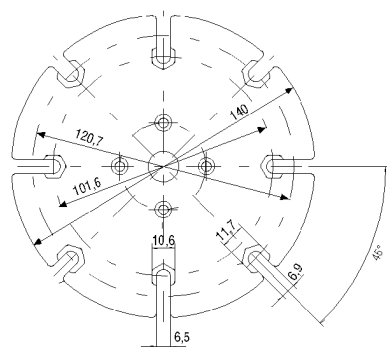
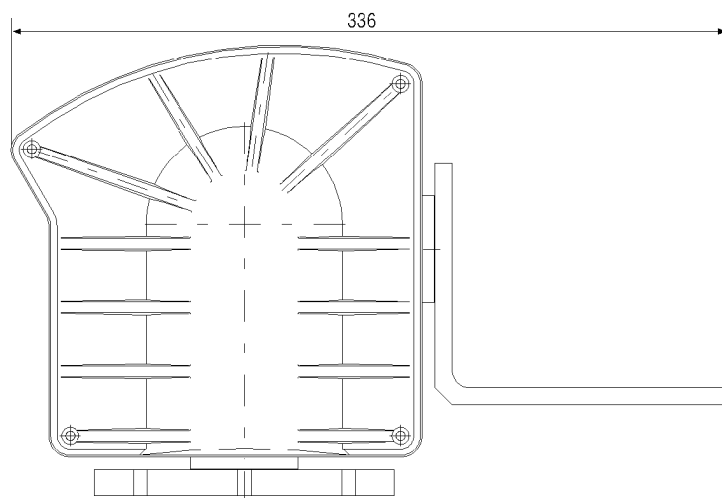
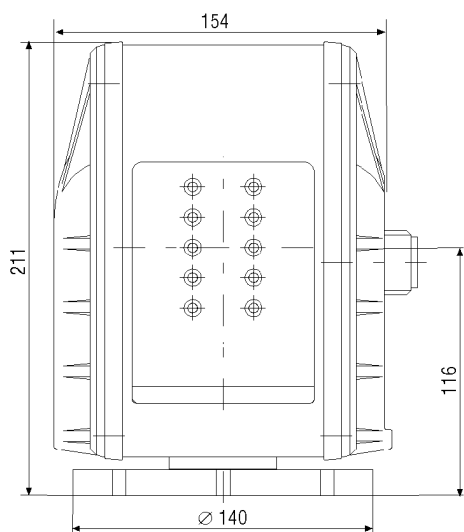

Maße/Dimensions: mm

e-mail: [info@eneo-security.com](mailto:info@eneo-security.com) • [www.eneo-security.com](http://www.eneo-security.com)