

Video Security

Dome Cameras | eneo Vandalism-Proof Fix Domes

VKCD-1314SM/VF

1/3" Colour Dome Camera, Surface Mount,
F1.5/4-9mm Lens, 12VDC, 480TVL

Art-No. 92056



Features

For Wall and Ceiling Surface Mount

Vandal and Tamper-Resistant

Tinted Lexan Bubble, 100mm

1/3" Progressive Scan CCD Sensor

Integrated F1.5/4-9mm Varifocal Lens w. DC Iris

Resolution of 480 Horizontal Lines

Wide Dynamic Function (WDR)

On-screen Menu Control / Camera Title Display

Back Light Compensation (BLC)

Automatic White Balance (ATW)

Manual 3-axis Camera Adjustment

For Easy Indoor and Outdoor Installation (IP65)

Specifications

Video standard	PAL
System	Colour
Sensor size	1/3"
Imager	CCD, Sony Progressive Scan Interline Transfer
Active picture elements	approx. 440,000, 752(H) x 582(V)
Synchronization	Internal
Signal-to-noise ratio	50dB (B&W, AGC OFF)
Sensitivity (at 50% video signal)	0,56Lux, at F1.2 (VT measurement result including bubble)
Horizontal resolution	480TVL
Rotation range	manual: 360°
Privacy Zone masking	4 Areas, Masking, X/Y start/end
Automatic gain control (AGC)	OFF/LOW/MID/HIGH selectable
Gamma correction	approx. 0.45
Automatic shutter (AES)	1/50 ~ 1/100.000sec. (not available during Auto Iris ON)
Integration rate	no
Wide dynamic range	On/Off switchable
Dynamic range (WDR)	60db

(Specifications continued)

Flickerless function	On/Off switchable
White balance (AWB)	2500 ~ 9500K, Automatic/Hold/User selectable
Backlight compensation	BLC, On/Off switchable
Aperture Correction (APC)	Horizontal and vertical
IR cut filter	no
Video outputs (type)	CVBS
Video outputs	1Vp-p, CVBS, 75ohms
Lens mount	integrated lens
Lens type	varifocal
Lens	F1,5 ~ 340/4 ~ 9mm with galvanometer driven iris
Application range	security
Nominal format size	1/3"
Aspherical technology	yes
Focal length	4-9mm
Horizontal angle of view	71-31,6°
Focus range	0.5m ~ ?
Iris control	DC
Mount	n/a
OSD function control	Main menu: Camera-ID no., Camera title/text, Colour/B&W switching, Sharpness, Mirror function, Positive/Negative switching. AWB: White balance red/blue, automatic. AE: Brightness, Flickerless, High speed shutter, Low speed shutter (DSS), AGC, Brightness. IR Filter (delay). WDR: Mode, BLC. Privacy Zones: Area, Masking, X/Y start/end. Display: OSD, Function display ON/OFF. Initial: Camera settings ON/OFF
Cable connection	Video (BNC), 12VDC (DC jack), RS-485 (2-pin terminal)
Serial interfaces	RS-485
Serial port	(control S/W, interface protocols: Pelco D, further upon request)
Temperature range (Operation)	-10° ~ +50°C
Heater	no
Protection rating	IP65, at installation according to the manual
Supply voltage	12VDC, (9 ~ 15VDC), 12VDC ±0,5V recommended
Power consumption	3.6watts max.
Vandalism resistant	yes
Bubble	100mm diameter, Vandal resistant 3mm -tinted-polycarbonate with high resistance
Colour (bubble)	tinted
Camera adjustment	3-axis camera adjustment: 360° horizontal rotation / +45° tilt rotation, 360° pan rotation
Camera fixing	no
Mounting	surface mount, wall mount
Housing	indoor housing, Die-cast aluminium with tinted polycarbonate bubble
Housing material	plastic
Colour (housing)	Pantone Cool Gray 1C

VKCD-1314SM/VF

(Specifications continued)

Dimensions (HxWxD)	See drawing
Weight	840g
Parts supplied	Mounting screw kit, Torx wrench key, Service monitor cable (Cinch plug), Guide pattern, Manual

Accessories

70447 / VT-PS12DC-5	Plug-in Power Supply Unit 100-240VAC 12VDC (1.0Amp), Regulated, with DC Plug
77773 / VT-PS12DCDT1	PSU 12VDC/1.0A, Regulated, Desktop Version, 1.8m Cables each w. open ends
88149 / 3/4" - M25X1.5	Thread Adapter 3/4" - Conduit Connection M25x1.5mm for Dome Surface Mount Housing
74126 / VDOME/WB1	Wall Mount Kit for Vandalism Resistant Dome Cameras SM/VF Series

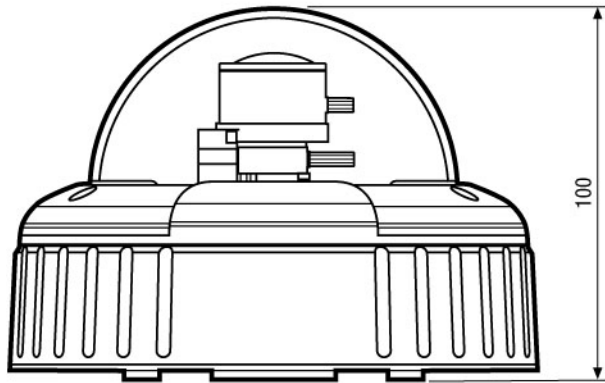
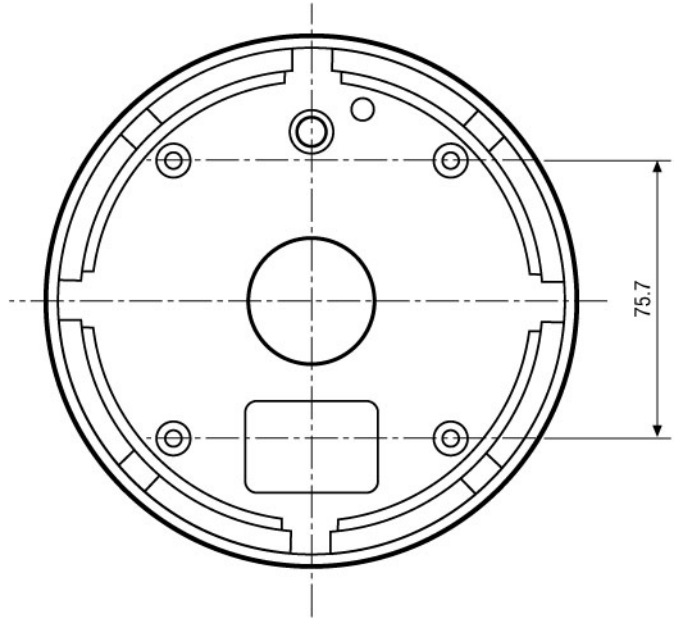
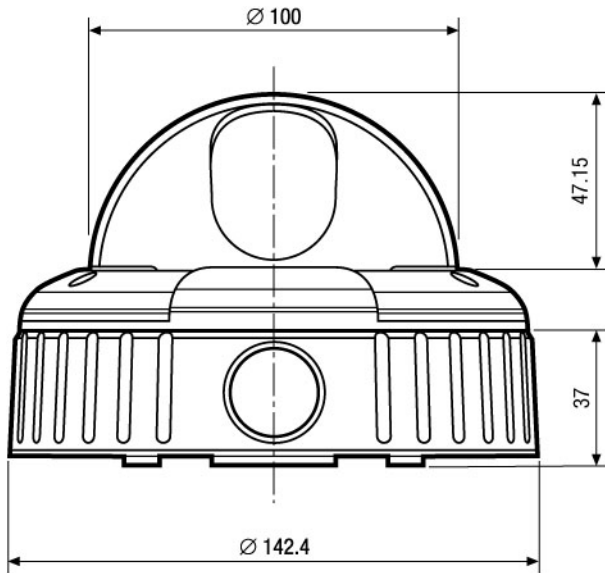

Maße/Dimensions: mm

VIDEOR TECHNICAL E. Hartig GmbH
 Carl-Zeiss-Straße 8 · 63322 Rödermark · Germany
 Telefon +49 (0) 60 74/8 88-0 · Telefax +49 (0) 60 74/8 88-100
 info@videortechnical.com · www.videortechnical.com

