

# Video Security

Dome Cameras | eneo Vandalism-Proof Fix Domes

## VKCD-1313SM/MF

1/3" Colour Dome Camera, Surface Mount  
with 3.8mm Lens, 12VDC, 550TVL

Art-No. 92054



## Features

For Wall and Ceiling Surface Mount  
Vandal and Tamper-Resistant  
Tinted Lexan Bubble, 100mm  
1/3" Colour Board Camera with Super HAD CCD  
Integrated Lens F2.0/3.8mm  
Resolution of 550 Horizontal Lines

Digital Signal Processing (DSP)  
Back Light Compensation (BLC)  
Automatic White Balance (ATW)  
Manual 3-axis Camera Adjustment  
For Easy Indoor and Outdoor Installation (IP65)

## Specifications

Video standard	PAL
System	Colour
Sensor size	1/3"
Imager	CCD, Sony Super HAD Interline Transfer CCD
Active picture elements	approx. 440,000, 752(H) x 582(V)
Synchronization	Internal
Signal-to-noise ratio	48dB
Sensitivity (at 50% video signal)	0,35Lux, at F1.2 (VT measurement result including bubble)
Horizontal resolution	550TVL
Rotation range	manual: 360°
Automatic gain control (AGC)	On/Off switchable
Gamma correction	approx. 0.45
Automatic shutter (AES)	1/50 ~ 1/100.000sec.
Integration rate	no
Flickerless function	On/Off switchable
White balance (AWB)	Automatic control
Backlight compensation	BLC, On/Off switchable

**VKCD-1313SM/MF**

(Specifications continued)

<b>Aperture Correction (APC)</b>	Horizontal and vertical
<b>IR cut filter</b>	no
<b>Video outputs (type)</b>	CVBS
<b>Video outputs</b>	1Vp-p, CVBS, 75ohms
<b>Lens mount</b>	integrated lens
<b>Lens type</b>	fixed focal length
<b>Lens</b>	F2.0/3.8mm with galvanometer controlled iris
<b>Application range</b>	security
<b>Nominal format size</b>	1/3"
<b>Aspherical technology</b>	no
<b>Focal length</b>	3,8mm
<b>Horizontal angle of view</b>	65°
<b>Iris control</b>	no
<b>Mount</b>	n/a
<b>Cable connection</b>	Video (BNC), 12VDC (DC jack)
<b>Serial interfaces</b>	no
<b>Temperature range (Operation)</b>	-10° ~ +50°C
<b>Heater</b>	no
<b>Protection rating</b>	IP65, at installation according to the manual
<b>Supply voltage</b>	12VDC, (9 ~ 15VDC), 12VDC ±0,5V recommended
<b>Power consumption</b>	3.0watts max.
<b>Vandalism resistant</b>	yes
<b>Bubble</b>	100mm diameter, Vandal resistant 3mm -tinted-polycarbonate with high resistance
<b>Colour (bubble)</b>	tinted
<b>Camera adjustment</b>	3-axis camera adjustment: 360° horizontal rotation / +45° tilt rotation, 360° pan rotation
<b>Camera fixing</b>	no
<b>Mounting</b>	surface mount, wall mount
<b>Housing</b>	indoor housing, Die-cast aluminium with tinted polycarbonate bubble
<b>Housing material</b>	plastic
<b>Colour (housing)</b>	Pantone Cool Gray 1C
<b>Dimensions (HxWxD)</b>	See drawing
<b>Weight</b>	840g
<b>Parts supplied</b>	Mounting screw kit, Torx wrench key, Service monitor cable (Cinch plug), Guide pattern, Manual

**Accessories**

<b>40072 / H0620M</b>	F2.0/6mm Board Camera Lens, 1/3" M12x0.5
<b>70447 / VT-PS12DC-5</b>	Plug-in Power Supply Unit 100-240VAC 12VDC (1.0Amp), Regulated, with DC Plug
<b>77773 / VT-PS12DCDT1</b>	PSU 12VDC/1.0A, Regulated, Desktop Version, 1.8m Cables each w. open ends

(Accessories continued)

88149 / 3/4" - M25X1.5

Thread Adapter 3/4" - Conduit Connection M25x1.5mm  
for Dome Surface Mount Housing

74126 / VDOME/WB1

Wall Mount Kit for Vandalism Resistant Dome Cameras  
SM/VF Series

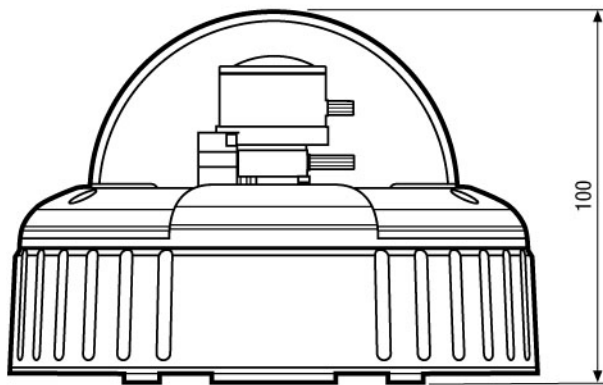
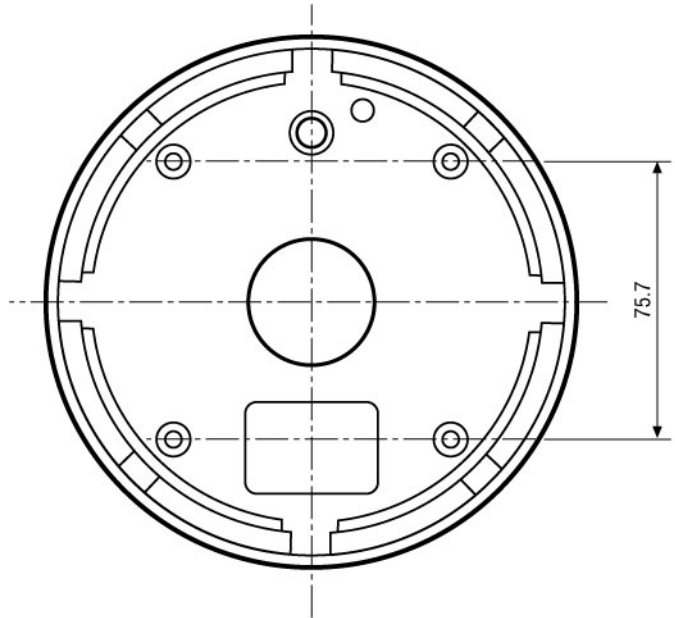
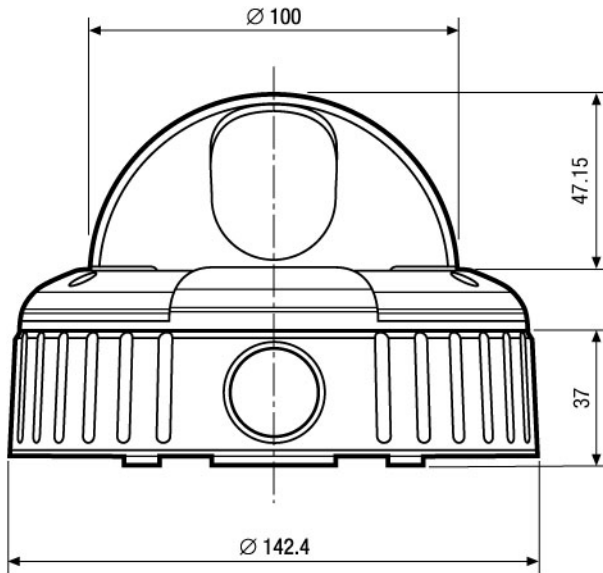

Maße/Dimensions: mm

VIDEOR TECHNICAL E. Hartig GmbH  
 Carl-Zeiss-Straße 8 · 63322 Rödermark · Germany  
 Telefon +49 (0) 60 74/8 88-0 · Telefax +49 (0) 60 74/8 88-100  
 info@videortechnical.com · www.videortechnical.com

