

# Video Security

Housings | eneo CANDID Housings

## VHU/DP-165

Candid dustproof Housing (165mm)

Art-No. 79481



## Features

Camera Dustproof Housing for Small Cameras  
Integrated Ball Point Head for Smooth Adjustment  
For Wall/Ceiling and Upright Mounting  
For Cameras with 12VDC, 24VAC Power Input

Insulated Camera Mounting  
4 Cable Entries  
Fully Hidden Cable Routing  
Index of Protection: IP54

## Specifications

|                             |   |
|-----------------------------|---|
| Maximum installation length | 165mm   |
| Clear Shield                | no  |
| Window heater               | no  |
| Sunshield                   | no  |
| Hidden cable management     | yes   |
| Cable entry                 | M25 x1.5mm cable gland with 4 entries for different cable diameters                       |
| Integrated wall mount       | yes   |
| Protection rating           | IP54  |
| Housing                     | indoor housing  |
| Housing material            | aluminium   |
| Colour (housing)            | RAL9016   |
| Colour                      | RAL9016 (Body and sunshield), RAL7035 (Front and back), RAL7037 (Inner ball, fixing ring) |
| Dimensions (HxWxD)          | See drawing   |
| Weight                      | 1kg   |
| Parts supplied              | 3mm Allen key, Bag of fixing screws   |

**Accessories****79494 / VHU-NT1**Power Supply Unit for Candid Housing Series  
230VAC/12VDC-14VAC(Camera/Heater)**79591 / VHU-NT2/1**Power Transformer for Candid Dustproof Housing,  
230V/24VAC**79499 / VHU-AKS/12-24V**Connecting Cable Set 12VDC/24VAC/Video for Candid  
Housing

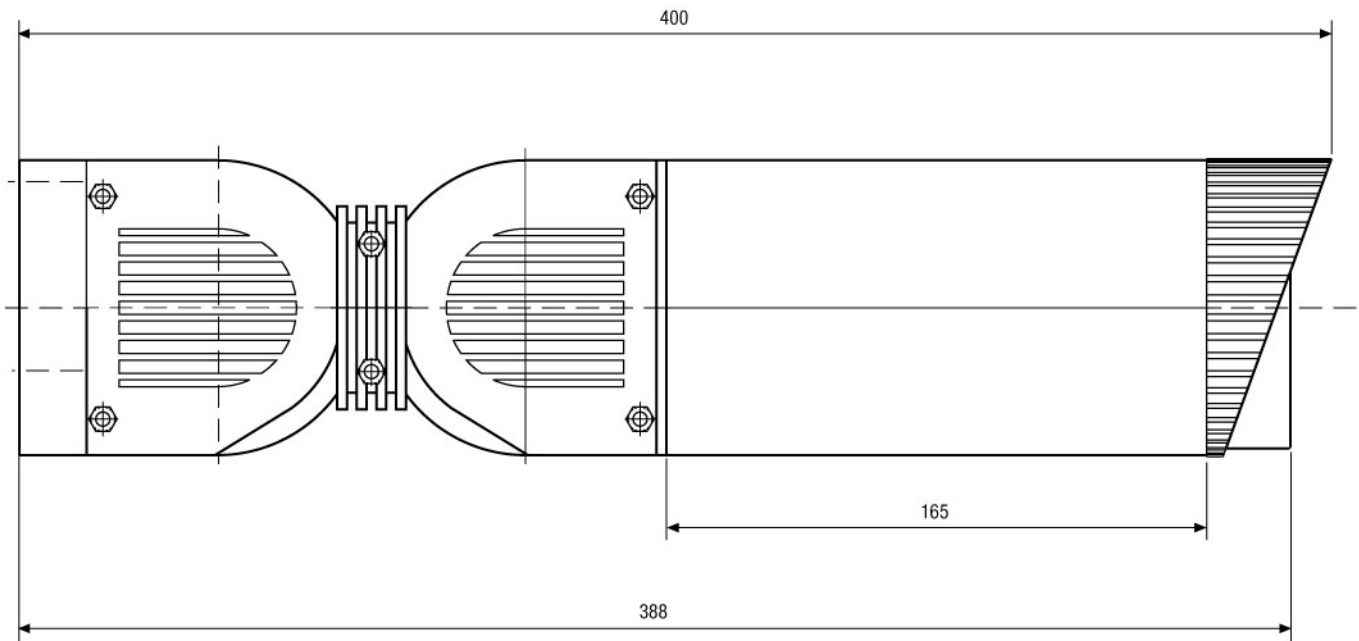
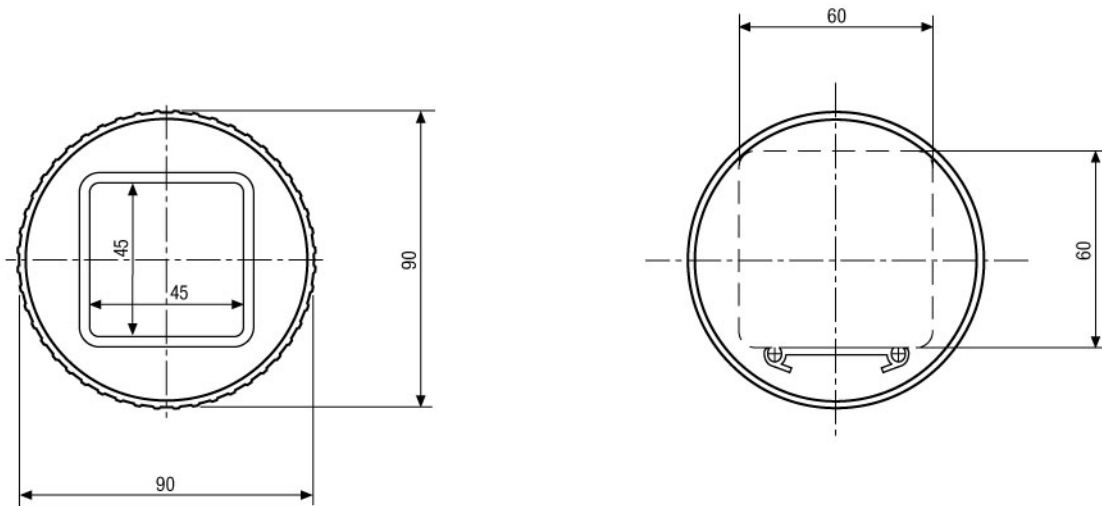

Maße/Dimensions: mm

VIDEOR TECHNICAL E. Hartig GmbH  
 Carl-Zeiss-Straße 8 · 63322 Rödermark · Germany  
 Telefon +49 (0) 60 74/8 88-0 · Telefax +49 (0) 60 74/8 88-100  
 info@videortechnical.com · www.videortechnical.com

