



Weatherproof Housings (Medium)

FDP-No.: 79404

VHM/ECLKA

- Camera Weatherprotection
- Housing Body Length: 330mm
- Fold-down Housing Body
- 4 Levels of Camera Height Adjustment
- Insulated Camera Mounting
- 3 Cable Entries
- Screen Heater Included
- Incorporated Carrier Handle
- Housing Surface: RAL7032



Wall bracket is not included with the housing

Specifications:

Maximum installation length	330 mm
Necessary space for PSU	NE-112 (1 output): 85 mm, NE-112/2 (2 outputs): 110 mm
Cable entries	3x PG9
Screen heater	110-265 V
Thermostat	On: +16°C, Off: +20°C
Sunshield	Yes
Protection rating	IP 66
Housing	Aluminium w. plastic end caps
Colour	RAL 7032
Dimensions (HxWxD)	See drawing
Weight	2.8 kg
Parts supplied	Screw set, thermostat switch, screw terminal

Accessories	
EDP No. / Type	Description
73064 WD-16/MK	Wall bracket with swivel head, recommended for housings VHB/VHM, light grey finish (RAL 7032)
71601 VHM/H24	Window heater 12-30 VAC/DC for VHL housing series
79382 VHM/KV	Screw terminal PCB for VHM housing series
79364 NE-112	Power supply unit 12 VDC-600 mA stabilized output voltage, with fuse 1.25 A, suitable for VHM housing series
79423 NE-112/2	Power supply unit 12 VDC-600mA stabilized, 24VAC-1A, suitable for VHM housings
79491 NE-112/AC24V	Power supply unit 230 VAC/24 VAC for VHM housing series
79418 VHM/WP-2	Screen wiper for VHM housing series, 24 VAC 50/60 z
79417 VHM/WP-1	Screen wiper for VHM housing series, 230 VAC/50 Hz
70599 VZS-6	Plugable twisted-pair video signal transmitter, 1 coaxial input, 1 TP output, 12 VDC

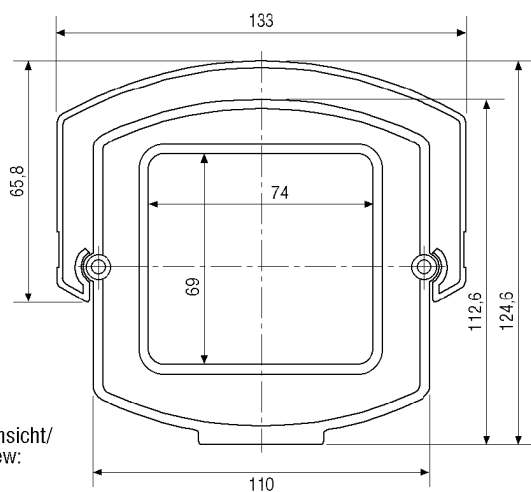

Vorderansicht/
Front view:

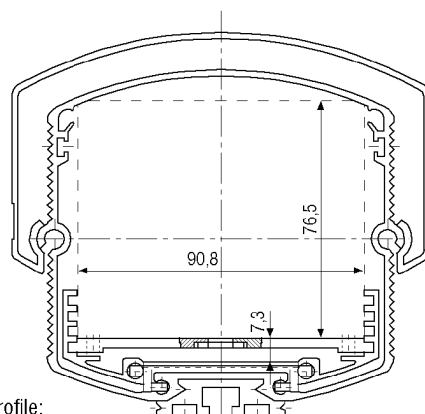

Profil/Profile:

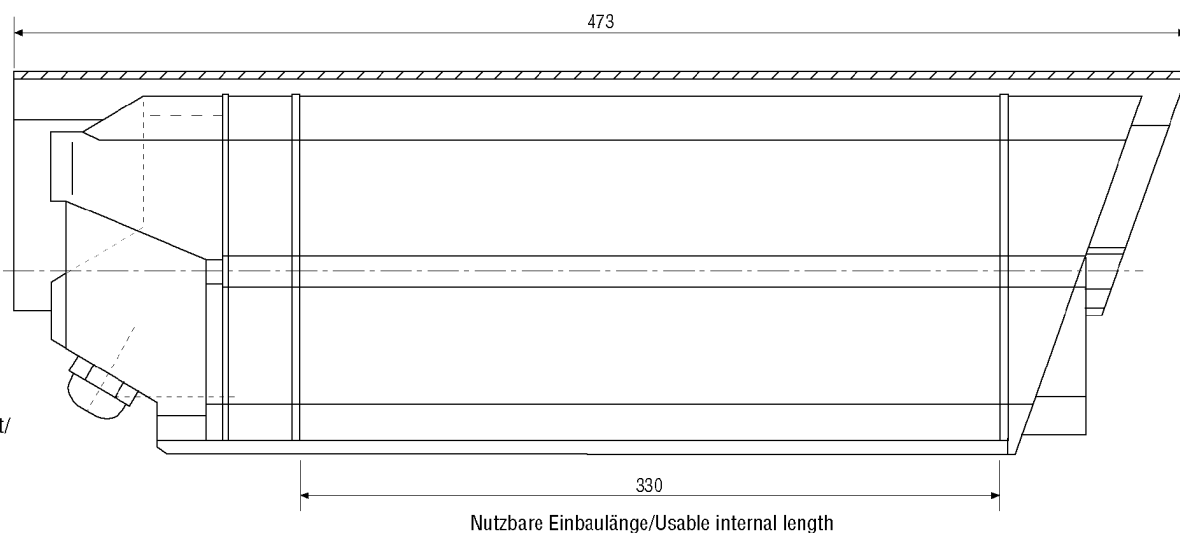

Seitenansicht/
Side view:

Nutzbare Einbaulänge/Usable internal length

Maße/Dimensions: mm