

# Video Security



## F06Z08NDDC

F1.2/6-48mm DC Motor Zoom Lens, 1/3" CS Mount

Art-No. 47419



## Features

Suitable for 1/2" and 1/3" Colour and B&W Cameras  
CS Mount  
DC Controlled Iris  
Lens Design Exclusive for Motorization

High Standard of Optical and Mechanical Quality  
Quality Motors on Focus and Zoom  
Adjustable Slip-ring Mount for Cable Positioning  
4-pin Connector for DC Iris Control

## Specifications

Nominal format size	1/3"
Focal length (f)	6-48 mm
Aperture range (F)	F1.2-F250
Iris control system	Galvanometer
Horizontal angle of view at nominal format size	44.3°-5.8°
Minimum object distance (M.O.D.)	1.0 m
Flange focal length	12.5 mm
Screw-in depth	4.2 mm
Filter screw size	M49x0.75 mm
Slip-ring mount	340°-360° Variable adjustment range
Cable length	>50 cm
Nominal voltage	8.0 VDC +/-20 %
Max. current consumption/motor (run)	25 mA
Response time	Approx. 6 sec. (at 8 V)
Motor clutch on focus/zoom	Yes
Connection	Cable length: 20 cm, with 4-pin DC plug
Lens mount	CS
Temperature range	-10°C to +50°C
Dimensions (HxWxD)	See drawing
Weight	390 g

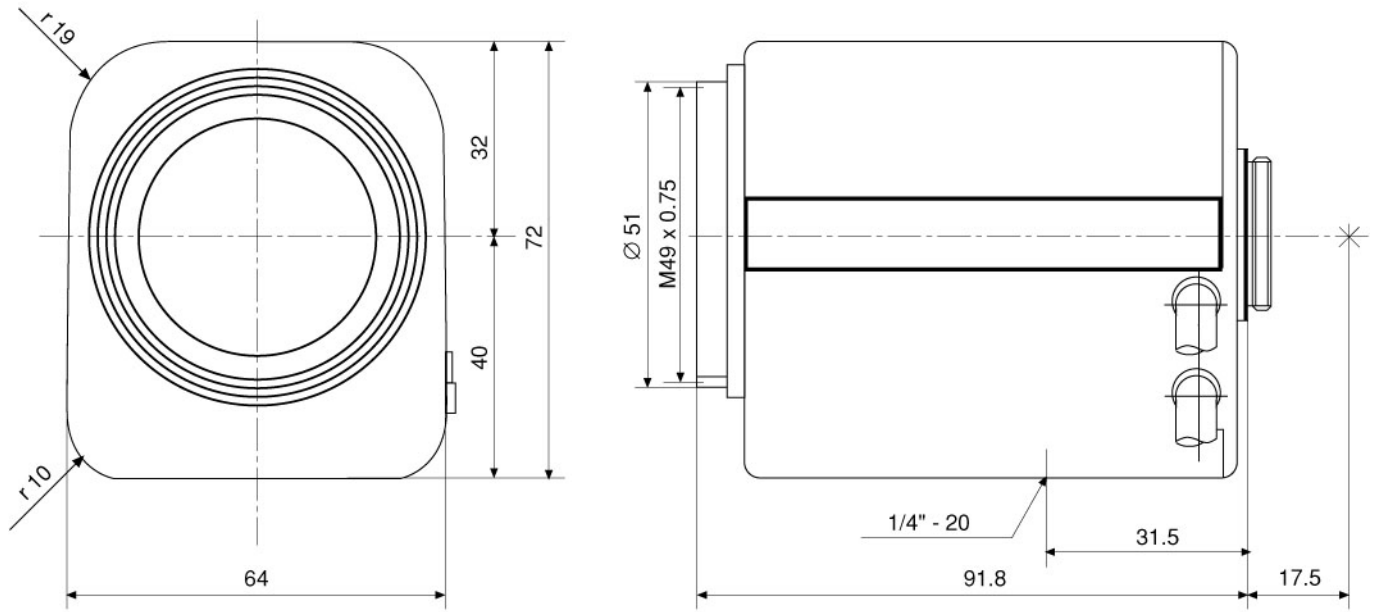

Maße/Dimensions: mm

VIDEOR TECHNICAL E. Hartig GmbH  
 Carl-Zeiss-Straße 8 · 63322 Rödermark · Germany  
 Telefon +49 (0) 60 74/8 88-0 · Telefax +49 (0) 60 74/8 88-100  
 info@videortechnical.com · www.videortechnical.com

