

Video Security



Lenses | Varifocal Lenses

F02Z02NDDC-MP

F1.2/2.4-6mm Megapixel DC Lens with variable Focal Length, 1/3" CS Mount

Art-No. 43259



Features

Suitable for 1/3" and Cameras >1MPixels
Variable Focal Length
Aspherical Lens Elements
CS Mount

High Standard of Optical and Mechanical Quality
4-pin Connector for DC Iris Control
Adjustable Slip-ring Mount for Cable Positioning

Specifications

Lens type	varifocal
Application range	security, megapixel
Aspherical technology	yes
Nominal format size	1/3"
Flange focal length	12.5mm
Mount	CS
Focal length	2,4-6mm
Horizontal angle of view	111,3-47,1°
Minimum object distance (M.O.D.)	0.3m
Aperture range (F)	F1.2 ~ F360
Iris control	DC
Iris control system	Galvanometer
Screw-in depth	4.7mm
Filter screw size	-
Cable length	approx. 25cm
4-pin plug	Standard
Temperature range (Operation)	-20°C ~ +60°C
Dimensions (LxDxH)	See drawing
Weight	75g

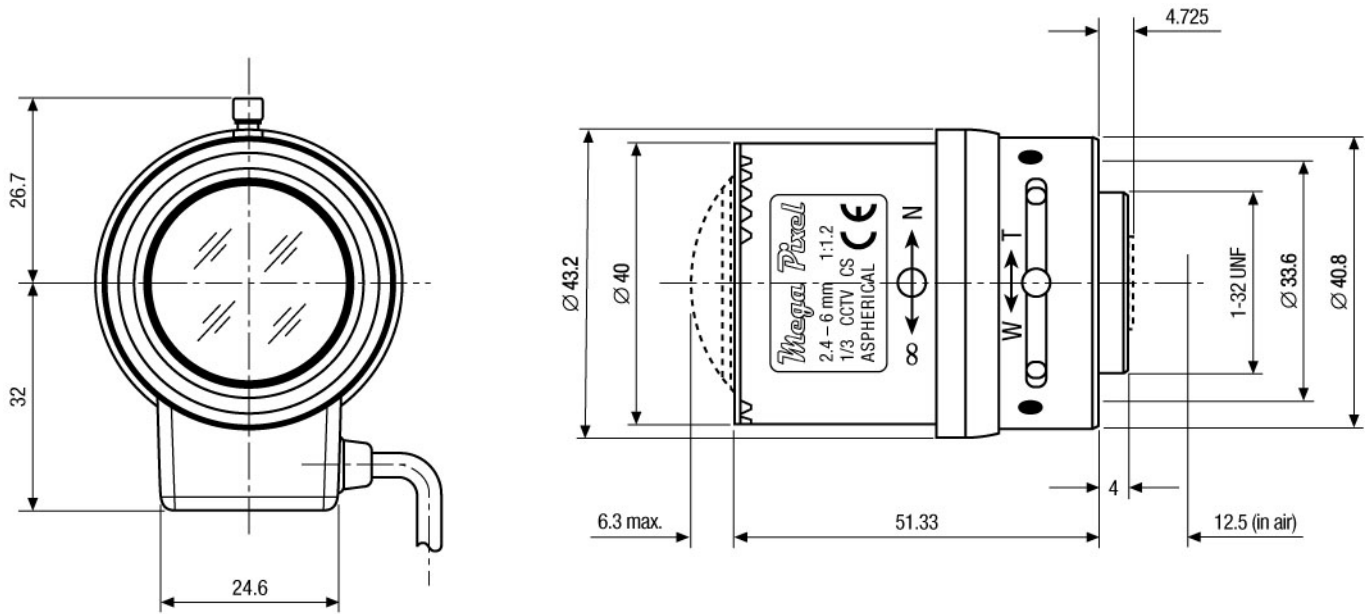

Maße/Dimensions: mm

VIDEOR TECHNICAL E. Hartig GmbH
 Carl-Zeiss-Straße 8 · 63322 Rödermark · Germany
 Telefon +49 (0) 60 74/8 88-0 · Telefax +49 (0) 60 74/8 88-100
 info@videortechnical.com · www.videortechnical.com

