

DH-PFM920I-6U-U

UTP CAT6 Cable



Network cables are the most commonly used transmission mediums in generic cabling system. It is usually composed of 4 pairs of twisted wires, and is generally applied in system cabling within 100 meters.

Features

- 305.0 m (1000 ft)/carton UTP CAT6, power over Ethernet, compatible with one cable
- High-purity Oxygen-Free Copper conductor material
- Customized PVC outer sheath; meet ANSI UL CM flame retardant class certified
- 10-year warranty

Technical Specification

Conductor

Material	Oxygen free copper (99.97% purity)
Diameter	0.57 mm ± 0.01 mm
American Wire Gauge	23AWG

Insulation

Material	HDPE
Min. Average Thickness	0.21 mm
Diameter	1.02 mm ± 0.06 mm
Color (4 Pairs)	Blue, white/blue; orange, white/orange; green, white/green; brown, white/brown

Separator

Material	PE
Specification	Translucent 4.5 × 0.4 mm

Rip Cord

Material	Polyester
Specification	500D

Sheath

Material	PVC
Min. Average Thickness	0.5 mm
Diameter	6.5 mm ± 0.3 mm
Color	White

Electrical

Max. DC Resistance of a Single Conductor	8.45Ω/100 m
Min. Insulation Resistance	5000MΩ·km
Max. DC Resistance Unbalance	2% (pair intra), 4% (pairs inter)
Dielectric Strength	No breakdown with 1KV DC for 1 min

Transmission

Characteristic Impedance	100 ± 15Ω
Near End Cross Talk	≥39.30 dB/100 m@250 MHz
Max. Attenuation	33 dB/100 m@250 MHz
Return Loss	≥17.3 dB/100 m@250 MHz

Mechanical

Tensile Strength	Sheath≥13.5 MPa, insulation≥13.8 MPa
Elongation at Break	Sheath≥200%, insulation≥300%
Installation Bending Radius	>8 times of outer cable diameter
Conductor Elongation at Break	≥20%

Environmental

Shrinkage of Insulation	≤5%
Color Migration Resistance of Insulation	No migration

Sheath Tensile Strength and Elongation at Break after Aging	≥12.5 MPa, ≥100%
Low Temperature Bending Test	No cracking after the test
Heat Shock Test	No cracking after the test
Operation Temperature	-20°C to +60°C (-4°F to 140°F)
Installation Temperature	0°C to +50°C (32°F to 122°F)
Storage Temperature and Humidity	-10°C to +40°C (14°F to 104°F), <60% (RH)

Security

Vertical Fire Propagation Test	Comply with UL1685
--------------------------------	--------------------

Packaging

Length	305.0 m (1000.66 ft) ± 1.5 m (4.92 ft)
Packaging Dimensions	390.0 mm x 390.0 mm x 247.0 mm (15.37"x15.37"x9.73") (L x W x H)
Packaging Method	305.0 m (1000.66 ft) a carton, one protection carton with 2 cartons inside
Net Weight	≥12.9 kg (28.44 lb)
Gross Weight	≥13.9 kg (30.64 lb)

Executive Standard

Executive Standard	ANSI/TIA 568-C.2, UL1685
--------------------	--------------------------

Certification

Certification	UL CM
---------------	-------

Ordering Information

Type	Part Number	Description
Network Cable	DH-PFM920I-6U-U	UTP CAT6 Cable

Dimensions (mm/inch)

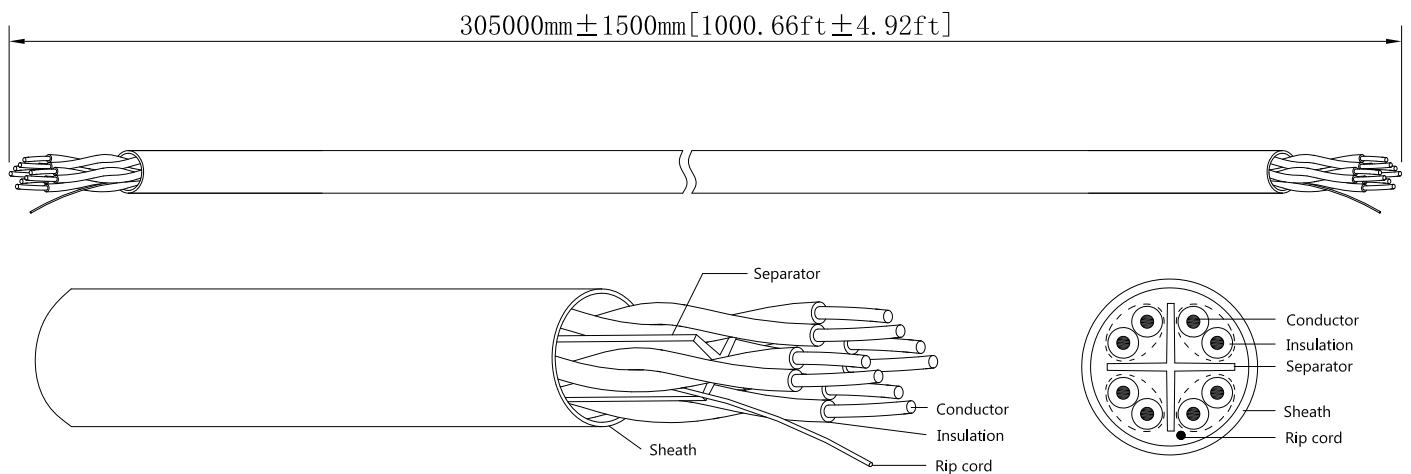

Package Information

· 305m UTP CAT6 cable *1