

6-pin Yale Format Cylinder

Part number: CL-6P2

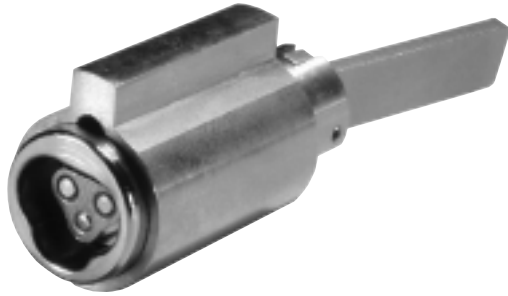

The CyberLock electronic 6-pin Yale format cylinder is based on the exact dimensions of the mechanical Yale format 6-pin cylinder. It is compatible with all lock hardware that utilizes this style of cylinder. Applications include knob and lever sets for doors and locks for cabinets and drawers.

Converting a mechanical lock to an electronic CyberLock access system is as easy as:

- Removing the mechanical cylinder.
- Installing the driver and tail piece from the mechanical cylinder onto the back of the CyberLock cylinder.
- Installing the new CyberLock cylinder into the lock.
- Using Videx's CyberAudit software to program (key) the lock.

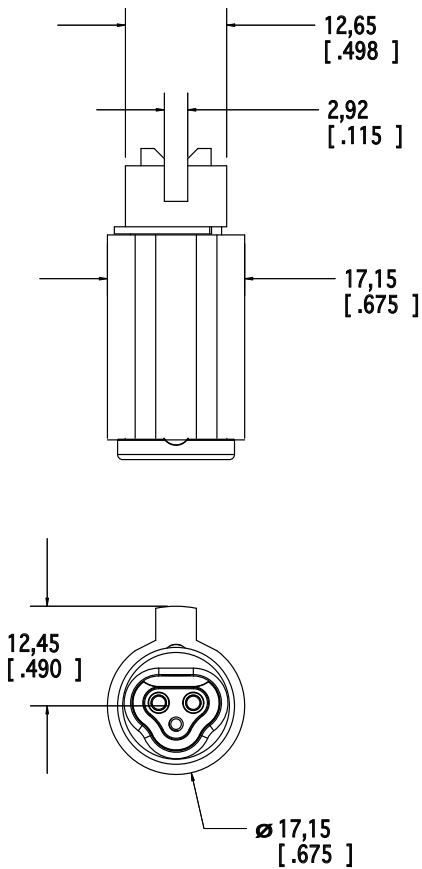

Notes:
 Dimensions in mm (inches)
 Drawing not to scale
 Ø indicates diameter

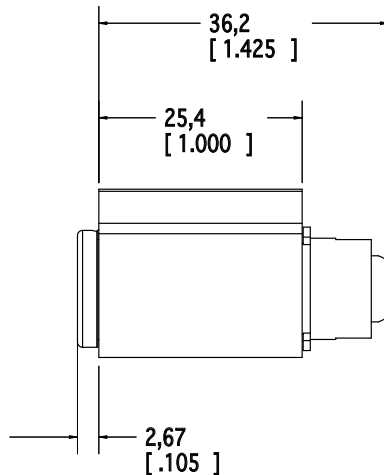

6-pin Yale Format Cylinder

Part number: CL-6P2

Specifications

Finish	<ul style="list-style-type: none"> • Brass with a nickel-plated front
Operating Temperature	<ul style="list-style-type: none"> • -40° to 160° F; -40° to 70° C, non-condensing
Power Requirements	<ul style="list-style-type: none"> • None; power is supplied by the key's battery.
Hardware Security Features	<ul style="list-style-type: none"> • No keyway to pick. • If torque is applied to the front of the cylinder, it separates from the back half leaving the cylinder in the locked position. • Resists electric charge applied to the face of the lock.
Hardware Options	<ul style="list-style-type: none"> • Tamper pin which blocks the locking pin automatically when impact force is applied to the front of the lock. • Hardened metal. • Drill-resistant pins.
Number of Keys per Lock	<ul style="list-style-type: none"> • No limit to the number of keys that the lock can support.
Number of Locks per Key	<ul style="list-style-type: none"> • Up to 3300 locks can be accessed with a standard user key. • A Master key has no limit to the number of locks it can access. • A database has no limit to the number of locks or keys it can manage.
Lost Keys	<ul style="list-style-type: none"> • The system can designate and disable lost keys.
Access Schedules	<ul style="list-style-type: none"> • Schedules programmed into the CyberKey provide complete control over specific days and times that a key will operate. A key can use up to 49 different schedules to access locks. • A database has no limit to the number of schedules it can manage. • Holidays may be set as exceptions to the schedules.
Audit Capacities	<ul style="list-style-type: none"> • The lock remembers the last 1100 events with date and time. • A key remembers up to 3900 events with date and time. It can be set to keep only the most recent set of events or to stop operating when its audit trail is full.
Electronic Security Features	<ul style="list-style-type: none"> • Key Expiration – a begin/end date range can be set during which the key will work. • Delayed entry – a lock can be set to delay entry for up to 20 minutes. • Multiple key custody – a lock may be set to require more than 1 key (up to 4) before opening.
Electronic Rekeying	<ul style="list-style-type: none"> • Rekeying a system is done via the software; no need to install new locks and issue new keys.