



[www.infographicsystems.com](http://www.infographicsystems.com)  
[www.GE-Interlogix.com](http://www.GE-Interlogix.com)

## RRE, RRE2, RRE2A and RRE4

Remote Reader Electronics Modules

### Overview

Utilization of two-stage access control readers with the ACU networked intelligent controller is accomplished using the Remote Reader Electronics (RRE) series of remote reader interfaces.

Four basic versions of the RRE are available: the standard RRE single reader controller, the RRE2 and RRE2A two reader controllers, and the RRE4, which provides control for up to four readers.

Each version has the capability to interface to keypads, door contacts, request-to-exit devices and provides 5 and 12-volt outputs to power readers and request-to-exit devices.

### Features

- Intelligent remote modules provide flexible and cost-effective reader and keypad interfacing, status monitoring and control capabilities.
- All RREs communicate with the ACU family of controllers, including the InVision panel, via RS-485 multi-dropped communication lines.
- Use of RREs on an ACU does not diminish the capacity to utilize Remote Input Modules (RIM) and Remote Relay Modules (RRM), except for 16 reader versions. See REN, RIM and RRM datasheet for further details.

### RRE and RRE2

- Interface reader and/or keypad using virtually any type of industry standard reader technology.
- Provides two local Form-C relays per reader (SPDT rating 30 VDC at 2 amps) which can be used for any control action specified by the system, including door strike activation.
- Provides four UL Grade AA supervised inputs for each reader, and one unsupervised input for tamper alarm.
- Interfaces to one (RRE) or two (RRE2) readers and/or keypads using Wiegand interfaces up to 500' from the RREs.

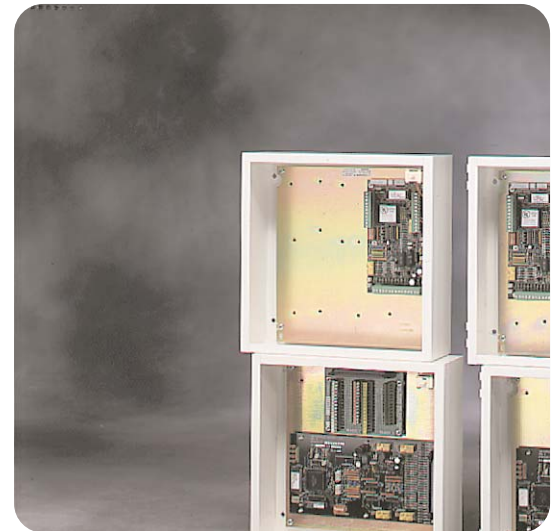

**RRE**

### RRE2A

- Interfaces up to two readers and/or keypads using Wiegand interfaces up to 500' from the RRE2A.
- Provides four Form-C relay outputs (SPDT rating 30 VDC at 2 amps).\*
- Provides eight UL grade AA supervised inputs and one unsupervised input for tamper alarm.

### RRE4

- Interfaces up to four readers and/or keypads using Wiegand interfaces up to 500' from the RRE4.
- Provides four Form-C relay outputs (SPDT rating 30 VDC at 2 amps).\*
- Provides eight UL grade AA supervised inputs and one unsupervised input for tamper alarm.

\* Can be used for any control action specified by the system, including door strike activation.

# RRE, RRE2, RRE2A and RRE4

## Reader Architecture

The ACU range of field controllers offer the flexibility of RRE installations in several configurations.

A two-stage reader configuration (for some proximity and certain types of Wiegand and smart card readers) can be used with one of four different RRE units separately mounted from the interface to the reader.

a. A single-reader (RRE) mounted above the door and interfaced to the read head.

b. A two-reader (RRE2 or RRE2A) or a four-reader (RRE4) mounted at a remote point in the system with the read heads, keypads, alarm points and door strikes connected to it from the door locations.

Each of these configurations also offer the choice of controlling the door lock from a relay at the ACU, or a relay on a RRM. Similarly, alarm inputs from the door may also be configured to an input on the ACU or on a RIM.

## Comparative Features of Remote Modules

Model No.	Enclosure Dimension	Includes	Max. Model Capacity	Inputs	Outputs	Power Supply
RRE-0**	No enclosure - back plate only	1 RRE	2 RRE	4	2	No
RRE-1	12" x 12" x 4" (30.5 x 30.5 x 10.2 cm)	1 RRE	2 RRE	4	2	No
RRE2-0**	No enclosure - back plate only	2 RRE	2 RRE	8	4	No
RRE2-1	12" x 12" x 4" (30.5 x 30.5 x 10.2 cm)	2 RRE	2 RRE	8	4	No
RRE2A-0**	No enclosure - back plate only	1 RRE2A	1 RRE2A	8	4	No
RRE2A-1	12" x 12" x 4" (30.5 x 30.5 x 10.2 cm)	1 RRE2A	1 RRE2A	8	4	No
RRE4-0**	No enclosure - back plate only	1 RRE4	1 RRE4	8	4	No
RRE4-1	12" x 12" x 4" (30.5 x 30.5 x 10.2 cm)	1 RRE4	1 RRE4	8	4	No

\* RREs can be powered from the 24 VDC ACU power supply.

\*\* Configurations without the enclosure do not comply with UL1076 and UL294 requirements.

## Six State Supervision

All alarm input points of the ACU, RRE and RIM are fully supervised using parallel/series end-of-the-line resistor network. Six-state supervision indicates all wiring conditions.

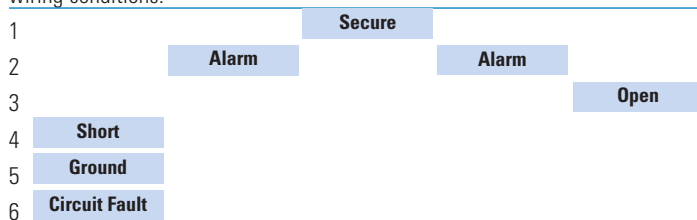

## Remote Reader Electronics Modules

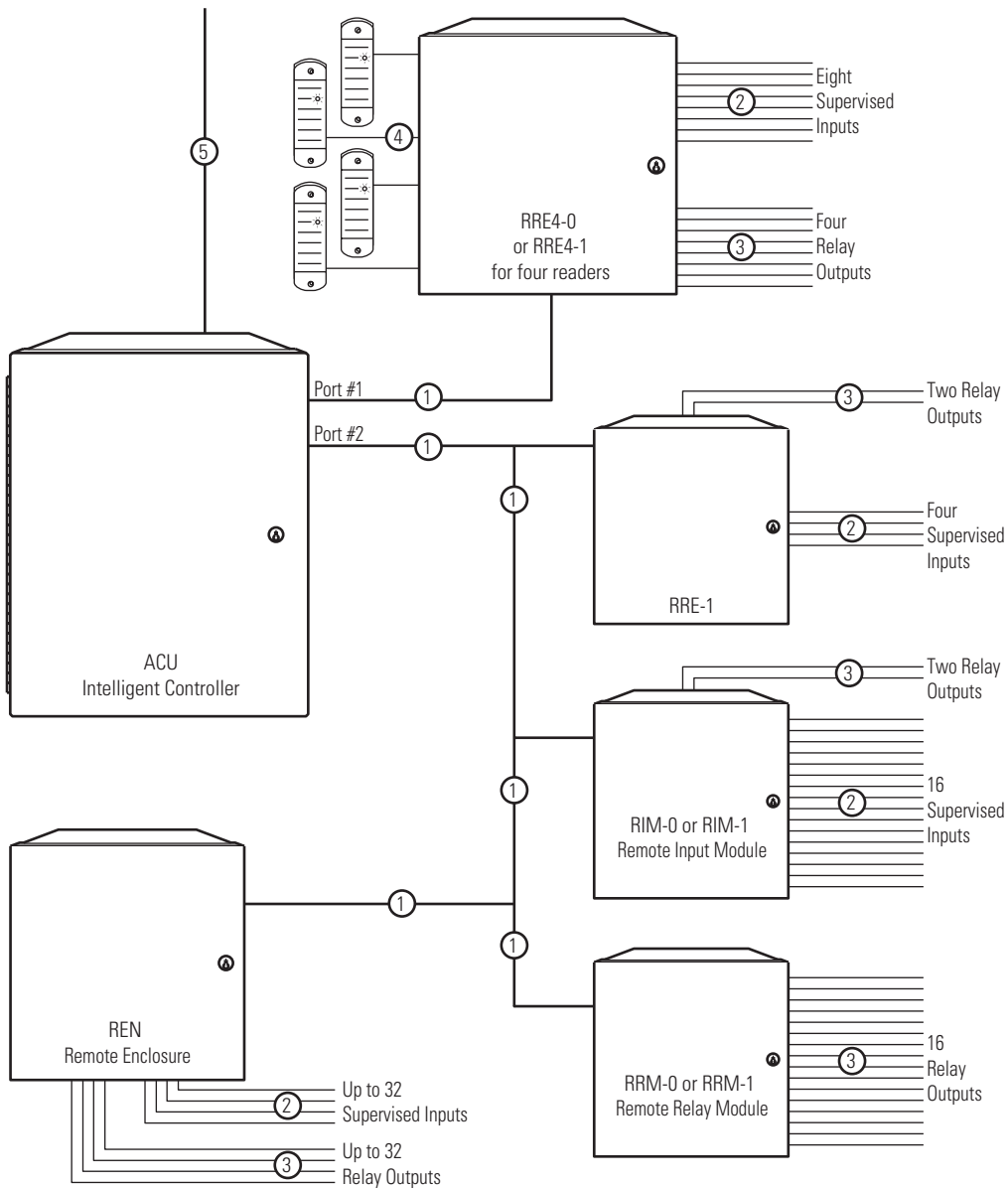

Cable #	Description	Belden Cable Number ( or equal)	Max. Distance
1	Communication (RS-485) Power (24 VDC) - varies with type of reader/keypad see manufacturer's installation instructions	#9842 or Alpha #6222C, 24 AWG, 2-pair, individual shields, braid overall shield And #9409 or Alpha #1897C, 18 AWG, 2-conductor/unshielded	4,000' (1,220 m)
2	Supervised input	#9407-22 AWG, 2-conductor (unshielded)	1,000' (305 m)
3	Relay output	#9409-18 AWG, 2-conductor (unshielded)	1,000' (305 m)
4	Standard reader communication	-	-
5	Host communication (RS-485)	#9842-24 AWG, 2-pair/shielded	4,000' (1,220 m)

# RRE, RRE2, RRE2A and RRE4

Remote Reader Electronics Modules

## Specifications

### Standards

All RRE modules are designed in accordance with the following standards:

- UL 294
- UL 1076
- CUL
- DCID 1/21
- FIPS 46-1
- MIL-STD 450B
- FCC CLASS A
- CE

### Dimensions

- Height: 12" (30.48 cm)
- Width: 12" (30.48 cm)
- Depth: 4" (10.16 cm)

### Environmental

- Maximum: +66 C (+150 F)
- Minimum: 0 C (+32 F)
- Humidity: 95%

## Ordering Information

Part Number	Product Description
<b>RRE Remote Reader Interface</b>	
RRE-0	No enclosure, includes back plate and printed circuit board
RRE-1*	Includes back plate, printed circuit board and enclosure with door tamper switch 12" H x 12" W x 4" D (30.5 x 30.5 x 10.2 cm)
<b>RRE2 Remote Reader Interface (2 readers)</b>	
RRE2-0	No enclosure, includes back plate and printed circuit board
RRE2-1*	Includes back plate, printed circuit board and enclosure with door tamper switch 12" H x 12" W x 4" D (30.5 x 30.5 x 10.2 cm)
<b>RRE2A Remote Reader Interface (2 readers)</b>	
RRE2A-0	No enclosure, includes back plate and printed circuit board
RRE2A-1*	Includes back plate, printed circuit board and enclosure with door tamper switch 12" H x 12" W x 4" D (30.5 x 30.5 x 10.2 cm)
<b>RRE4 Remote Reader Interface (4 readers)</b>	
RRE4-0	No enclosure, includes back plate and printed circuit board
RRE4-1*	Includes back plate, printed circuit board and enclosure with door tamper switch 12" H x 12" W x 4" D (30.5 x 30.5 x 10.2 cm)
* Only complete unit with enclosure complies with UL1076 and UL294	
<b>Optional</b>	
RRL	Enclosure lock, keyed same as ACU
RRE-PB	Enclosure with tamper switch



**GE Interlogix**  
InfoGraphics

[www.infographicsystems.com](http://www.infographicsystems.com)  
[www.GE-Interlogix.com](http://www.GE-Interlogix.com)

7373 Lincoln Way  
Garden Grove, CA 92841  
Phone: 714-890-0083  
Fax: 714-890-0093

12345 SW Leveton Drive  
Tualatin, OR 97062  
Phone: 503-692-4052  
USA & Canada: 800-547-2556  
Technical Service: 800-648-7424  
Faxback: 800-483-2495