

LTC 9418 Series Weatherproof Outdoor Pan/Tilts

- Maximum Load - 10 kg (22 lb)
- Low Profile, Compact Size
- Corrosion Resistant Hardware
- 100% Duty Cycle Motors
- Upright or Inverted Operation
- Pre-position Models Available



The LTC 9418 Series Weatherproof Outdoor Pan/Tilts are low profile, compact units constructed with corrosion resistant hardware. These remote positioning devices are rated for a maximum load of 10 kg (22 lb) and are fully system compatible with CCD cameras, lenses, and housing combinations.

The 100% duty cycle motors permit continuous operation on all models. Low speed worm drives and flexible motor mounts offer quiet, smooth motion. The use of impedance and overload protected motors, long life limit switches, and permanently lubricated bearings reduce maintenance and provide reliable operation.

SPECIFICATIONS

Electrical

Model No. ¹	Rated Motor Voltage and Voltage Range
Standard Models	
LTC 9418/60	110 VAC, 60 Hz, 108 to 132
LTC 9418/20	24 VAC, 60 Hz, 21.6 to 26.4
LTC 9418/10	24 VAC, 50 Hz, 21.6 to 26.4
LTC 9418/50	220 VAC, 50 Hz, 207 to 253
Pre-position Models	
LTC 9418/61	110 VAC, 60 Hz, 108 to 132
LTC 9418/21	24 VAC, 60 Hz, 21.6 to 26.4
LTC 9418/11	24 VAC, 50 Hz, 21.6 to 26.4
LTC 9418/51	220 VAC, 50 Hz, 207 to 253

1. The total power for all models, with both motors running, is 24 W.

Connectors:

Power: Via 24-pin connector on base.
Ground: Screw connection for grounding on base.

Recommended Applications

Designed for use with the following housings and appropriate camera/lens combinations up to 10X zoom:

TC9340A
LTC 9383 Series
LTC 9385 Series
LTC 9388 Series
LTC 9480/00
LTC 9483 Series
LTC 9488 Series

Recommended Maximum Cable Lengths:

Model Voltage	Wire Size		Distance	
	mm ²	AWG	Feet	Meters
24 VAC	0.5	20	140	43
	1	18	230	70
	1.5	16	360	110
	2.5	14	590	180
	4	12	940	287
115 VAC	0.5	20	2200	671
	1	18	3500	1067
	1.5	16	5500	1677
	2.5	14	9000	2744
230 VAC	0.5	20	13400	4085
	1	18	21200	6463
	1.5	16	33300	10152
	2.5	14	54400	16585

1. Values calculated at 20 °C (68 °F) using stranded tinned copper wire, a common ground (neutral), and with both PAN and TILT motors operating simultaneously.

Mechanical

Mounting: These units are designed for either upright or inverted installations. To maintain weatherproof integrity when mounting outdoors in an inverted position, the unit must be installed in a weatherproof enclosure (e.g., weatherproof domed housing) or a protected outside area. They can only be mounted upright or inverted; never horizontally.

Pan Range (Movement in horizontal plane): 0° to 345° maximum.

Pan Speed: 7°/sec.

Tilt (Movement in vertical plane): +30° to -90° from horizontal.

Tilt Speed: 3.5°/sec.

Maximum Load: 149 kg-cm (129 lb-in) torque or 10 kg (22 lb) at a distance of 63.5 mm (2.5 in) from the center of mass of the camera/lens/housing assembly to the center of the tilt table.

Construction: Cast aluminum base and yoke, corrosion resistant plastic cover.

Finish: Mushroom.

Dimensions: See Dimensional Outline.

Weight: 6.21 kg (13.7 lb).

Environmental

Temperature:

Operating: -30 °C to +60 °C (-22 °F to +140 °F).
Storage: -40 °C to +60 °C (-40 °F to +140 °F).

Vibration: 3 g swept sine wave, 15 Hz to 2000 Hz.

Shock: 50 g, 11 ms, 1/2 sine.

Enclosure: Tested to IP54 requirements (upright mounting). UL 50 Type 3/NEMA-3 design.

Electromagnetic Compatibility

EMC Requirements:

50 Hz Models: 89/336/EEC.

Immunity: EN50082-1.

Emission: EN50081-1 Class B.

Safety:

50 Hz Models: CE.

LVD Requirements: 73/23/EEC; EN60950.

60 Hz Models: UL & cUL.

UL: UL 2044.

cUL: CSA 22.2, No.1.

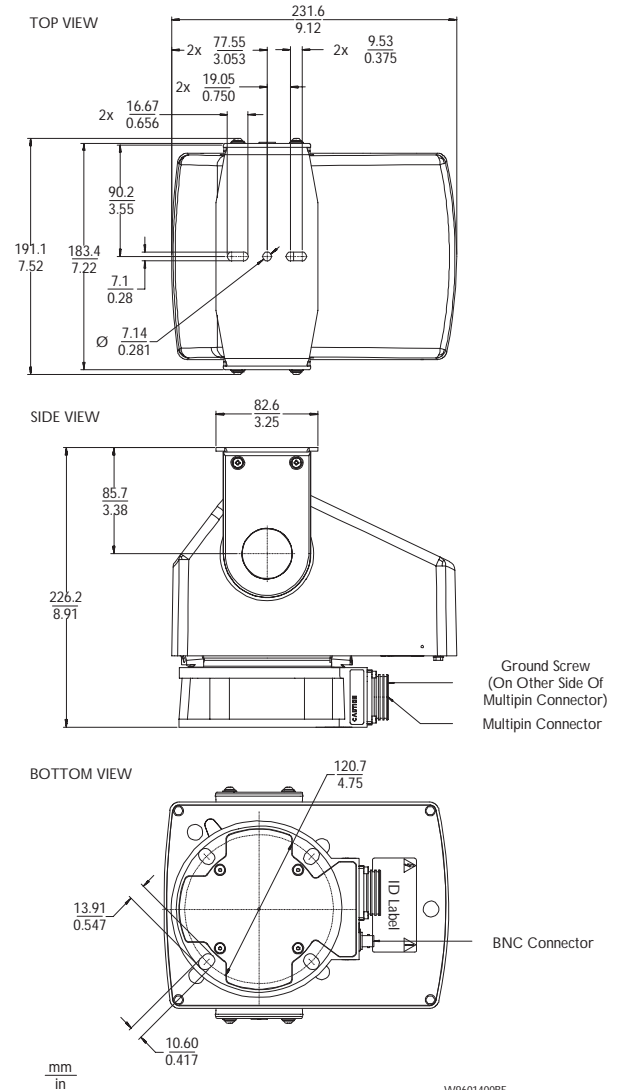

Dimensional Outline



PHILIPS

Let's make things better.