



# LTC 9365/00 Indoor Housing



- ▶ **Compact Design**
- ▶ **Hinged Design & Latch for Easy Installation**
- ▶ **Scratch-resistant Window**
- ▶ **Polycarbonate Housing & Window**
- ▶ **Tamper-resistant Fasteners**
- ▶ **Lightweight**
- ▶ **Fully Adjustable Camera Bracket**

The LTC 9365/00 is an attractive and compact ceiling wedge housing. It can be used with most standard CCTV camera and lens combinations, up to 203 mm (8-inch) in length.

Both the housing and the viewing window are made of lightweight, impact-resistant polycarbonate, and include tamper-resistant screws for increased security. Included in the housing is a fully adjustable camera bracket that allows the camera to be top or bottom mounted. Additionally, the hinged design and snap fit allow for easy installation and future servicing.

## Installation/Configuration Notes

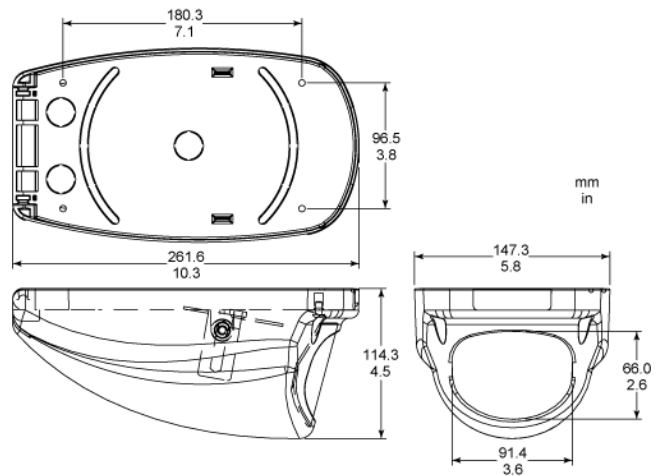

*Dimensional Outline*

## Parts Included

Quantity	Component
1	LTC 9365/00 Indoor Housing

## Technical Specifications

### Mechanical

Model No.	Description
LTC9365/00	In-ceiling Wedge Housing
Max Camera/Lens Length	203.2 L x 88.9 W x 76.2 H mm (8 L x 3.5 W x 3 H inch).
Cable Entry	Wire access through one of three possible locations on rear of housing.
Cover	Secured by two (2) tamper-resistant screws.
Mounting	Ceiling-mounted using four (4) screws.
Window	Clear, polycarbonate.
Construction	Polycarbonate.
Finish	Off-white.
Dimensions	See Dimensional Outline.
Weight:	0.45 kg (1 lb).
Use with Bosch Cameras & Lenses	
Camera	Lens
LTC0335	Fixed, Varifocal
LTC0355	Fixed, Varifocal
LTC0435	Fixed, Varifocal
LTC0455	Fixed, Varifocal

### Ordering Information

LTC 9365/00 Indoor Housing for ceiling surface mount, camera lens up to 200 mm (8 inch)	LTC9365/00
---	------------

**Europe, Middle East, Africa:**  
Bosch Security Systems B.V.  
P.O. Box 80002  
5600 JB Eindhoven, The Netherlands  
Phone: + 31 40 2577 284  
Fax: +31 40 2577 330  
emea.securitysystems@bosch.com  
www.boschsecurity.com

**Americas:**  
Bosch Security Systems, Inc.  
130 Perinton Parkway  
Fairport, New York, 14450, USA  
Phone: +1 800 289 0096  
Fax: +1 585 223 9180  
security.sales@us.bosch.com  
www.boschsecurity.us

**Asia-Pacific:**  
Bosch Security Systems Pte Ltd  
38C Jalan Pemimpin  
Singapore 577180  
Phone: +65 6319 3450  
Fax: +65 6319 3499  
apr.securitysystems@bosch.com  
www.boschsecurity.com

**Represented by**