



LTC 8500 Series Allegiant Matrix/Control Systems - Modular



- ▶ 64 Camera by 8 monitor switching
- ▶ 8 Independent keyboards
- ▶ Modular construction
- ▶ Powerful alarm handling capabilities
- ▶ SalvoSwitching and SatelliteSwitch capability
- ▶ PC-based software package available

The LTC 8500 Series Allegiant Video Switcher/Control Systems combine both switching and computer technology to provide powerful performance and unique system features for the security user. Offering full matrix switching capability, these systems can be programmed to display the video from any camera on any monitor, either manually or via independent automatic switching sequences.

The LTC 8500 Series provide versatile modular construction accommodating up to 64 camera inputs, 8 monitor outputs, 8 keyboards, 128 alarm points, a computer interface port, and a logging printer port.

Functions

Sequencing Capabilities

These systems can be programmed with up to 60 sequences which can be run independently of each other in either a forward or reverse direction. Any of the sequences can utilize the Salvo Switching capability where any number of system monitors may be selected to switch as a group. Using the optional LTC 8559/00 Master Control Software package or LTC 8850/00 GUI Allegiant Server, sequences can be made to activate and

deactivate automatically based upon the time of day and the day of week.

Camera Control

On-site receiver/drivers permit operator control of pan, tilt, zoom, multiple pre-positions, four auxiliaries, auto-pan, and random scan. An integral local test function is also a standard feature. The LTC 8500 Series also supports variable speed operation and full programming functions of AutoDome series dome cameras.

Bilinx® Capability

When combined with an LTC 8016 Allegiant Bilinx Data Interface unit, these switchers/controllers support operations using Bilinx communication. With Bilinx, PTZ control is accomplished using a bi-directional communication protocol embedded in the video signal of Bosch Dinion and AutoDome® CCTV cameras. In addition, Bilinx uses the standard video cable to transmit alarm and status messages from the cameras, providing superior performance without the need for separate data transmission cables.

Macro Capabilities

The LTC 8500 system provides powerful macro capabilities. The macros can be activated using Allegiant

system keyboards, system time event functions, alarm activations, and via special function icons in the LTC 8850/00 GUI software.

Alarm Capabilities

With the addition of the LTC 8540/00 Series alarm interface accessory unit, an external contact closure or logic level can be used to automatically activate any camera to be displayed. Any monitor or group of monitors can be set to display cameras under alarm conditions. The base system contains three built-in alarm response modes: basic, auto-build, and sequence and display. In addition to these three modes, the PC based software packages now includes the ability to combine any or all three standard modes within the same system. Alarm video may be selected to reset either manually or automatically. In addition, a 16-character alarm title can be selected to appear instead of the camera title during alarm conditions.

System Operation

System operation and programming is accomplished using a full-function, ergonomically designed keyboard. Up to 8 keyboards may be used in the system. Built-in operator priority levels and the ability to restrict certain operators from controlling designated functions provide maximum flexibility.

Programming/Software Capabilities

The LTC 8500 Series includes a 48-character on-screen display for time-date, camera number, camera ID (16 characters), an icon to identify controllable cameras, and monitor (12 characters) or status information. Over 250 characters are available when programming camera ID and monitor titles.

Utilizing a Windows-based PC and the LTC 8059/00 Master Control Software package or LTC 8850/00 Graphical User Interface (GUI) software, enhanced programming and switching features can be obtained. A user-friendly spreadsheet format provides the ability to enter camera titles, operator names, 64 timed events, change system parameters, program camera sequences, install lockouts, and access the advanced alarm handling screens with speed and efficiency. The program information may then be transferred into the Allegiant system, stored on disk, or printed out directly from a printer connected to the PC.

The LTC 8850/00 Bosch GUI software is designed around an intuitive graphic-based interface; the GUI provides high performance programming, control and monitoring of all system functions by using on-screen icons to reflect real time status of the devices controlled by the system.

The LTC 8850/00 GUI software also provides the ability to monitor system status events. System alarms, switching functions, sequence events, keyboard actions, and video loss information can be viewed in real time on the PC screen and, if desired, logged to the PC hard drive.

The LTC 8500 Series contains a logging printer output port which accepts a standard RS-232 serial printer. This provides a permanent record of system status showing time and date of changes, such as: incoming alarms, acknowledgment of alarms, loading of sequences, user log-on to keyboard, transfer of system tables and sequences, and a power up reset message. In addition, the printer can be used to obtain a hard copy of the system's configuration tables and sequences.

Expansion Capabilities

The LTC 8500 Series can serve as the Master switcher in a SatelliteSwitch configuration. This innovative SatelliteSwitch feature enables a single LTC 8500 Series system to communicate with up to 64 remotely located "Satellite" systems. Any Allegiant system model can serve as a remote Satellite switcher. This powerful feature permits the design of a distributed type system. The main control site can view/control local cameras plus cameras located at any of the remotely distributed Satellite sites. The Satellite sites can view/control only cameras associated with their own site. When used in this type of configuration, the main LTC 8500 Series system can access up to 256 cameras located anywhere in the system.

Certifications and Approvals

Electromagnetic Compatibility (EMC)	Complies with FCC Part 15, ICES-003, and CE regulations
Product Safety	Complies with CE regulations, UL, CSA, EN, and IEC Standards

Installation/Configuration Notes

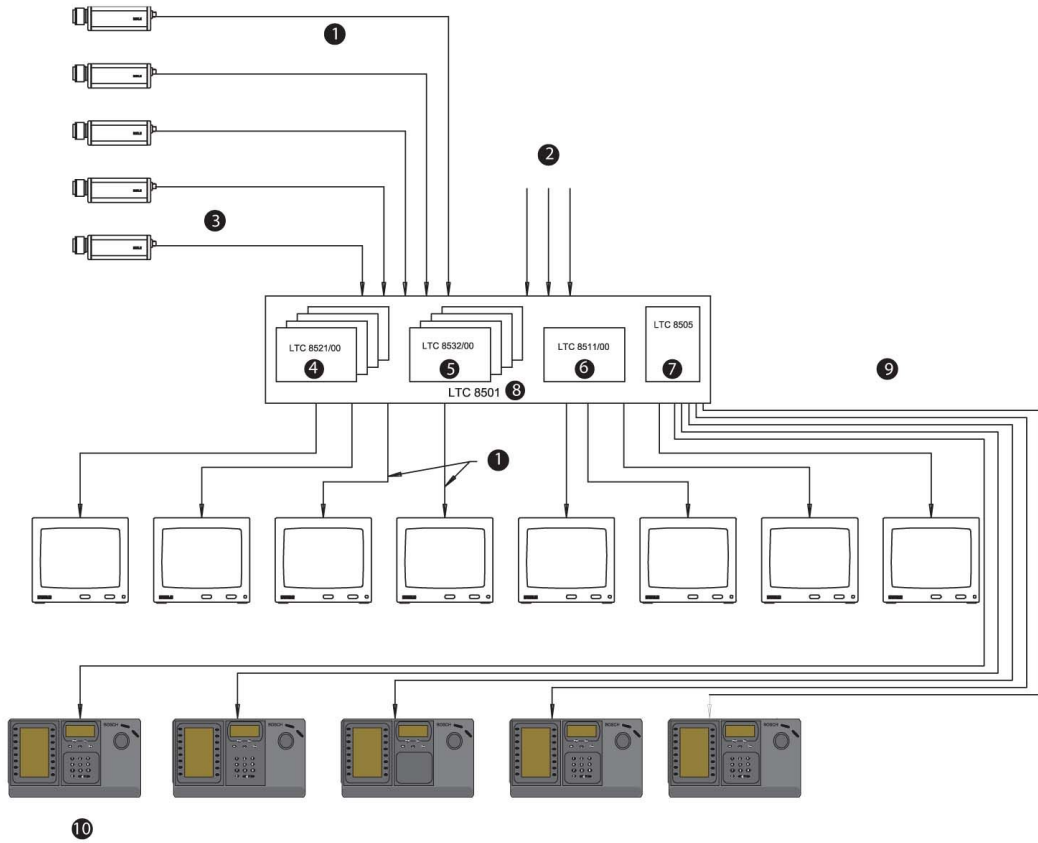

LTC 8500 Series Configuration Diagram
(64 Cameras by 8 Monitors)

- | | |
|---|---|
| <ul style="list-style-type: none"> 1 Video Coax 2 Up to 64 Maximum Video Inputs 3 Additional System Cameras 4 8 x 8 Channel Input Cards 5 4 x 2 Channel Output Cards | <ul style="list-style-type: none"> 6 CPU Module 7 Power Supply Module 8 Main CPU Bay 9 3 m (10 ft) Interconnect Cable Supplied with Keyboard 10 Maximum of 8 Full Function Keyboards up to 1.5 km (5000 ft) away using Optional Remote Hook-up Kit |
|---|---|

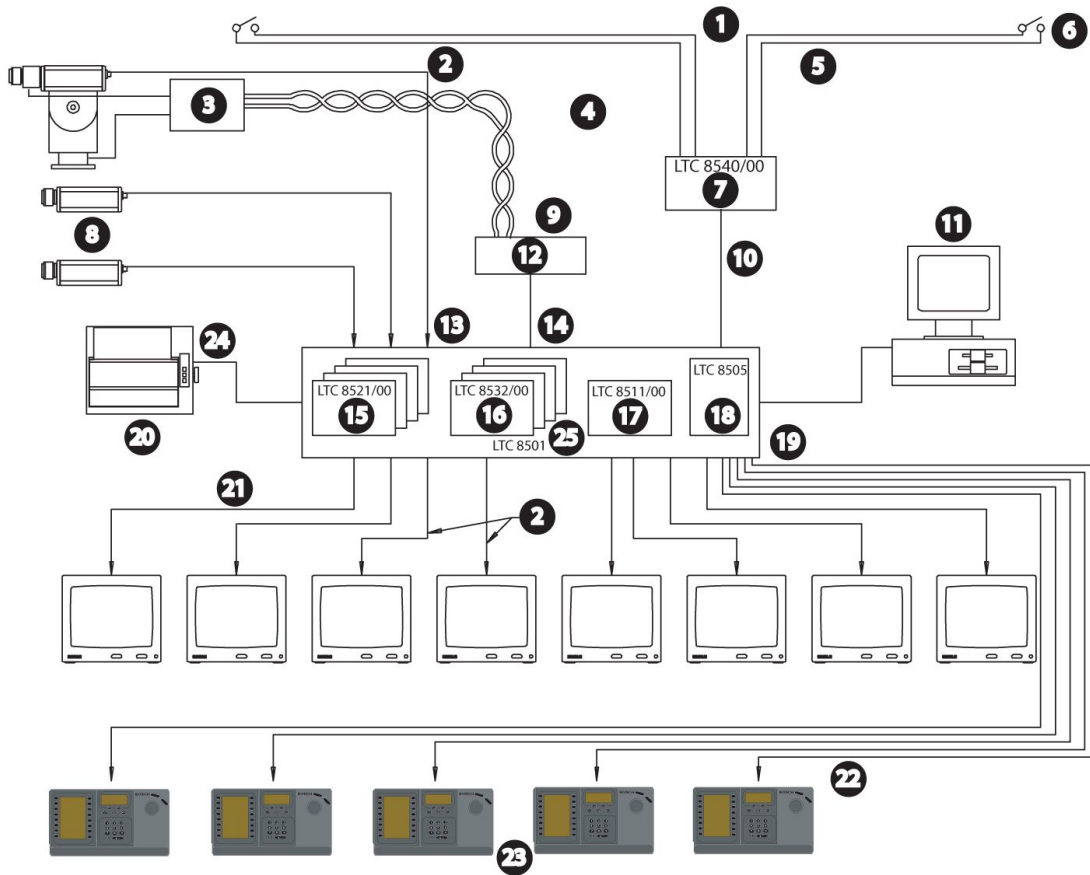

LTC 8500 Series Full Capacity Configuration Diagram

1	64 Separate Alarm Inputs	8	Additional System Cameras	14	2 m (6 ft) Interconnect Cable Supplied with LTC 8568/00 Series, providing Data and Power Connections	20	Serial Logging Printer Capability
2	Video Coax	9	32 Separate Outputs	15	8 x 8 Channel Input Cards	21	8 Monitor Output Capability
3	Up to 64 On-Site LTC 8561 Receiver/Driver Units	10	2 m (6 ft) Interconnect Cable Supplied with LTC 8540/00 Series, providing Data and Power Connections	16	4 x 2 Channel Output Cards	22	3 m (10 ft) Interconnect Cable Supplied with Keyboard
4	Up to 1.5 km (5000 ft) using 18 AWG shielded twisted pair cable (Belden 8760 or equiv.)	11	Optional LTC 8059/00 Software Package can be run on a Windows based PC	17	CPU Module	23	Maximum of 8 Full Function Keyboards Up to 1.5 km (5000 ft) away using Optional Remote Hook-up Kit
5	Twisted Pair, Typical	12	Signal Distribution Unit	18	Power Supply Module	24	RS-232 Data
6	Contact closure or active low logic level	13	Up to 64 Video Inputs Maximum level	19	3 m (10 ft) Interface Cable Provided with Optional LTC 8059/00 Software Package	25	Main CPU Bay
7	Alarm Interface Unit						

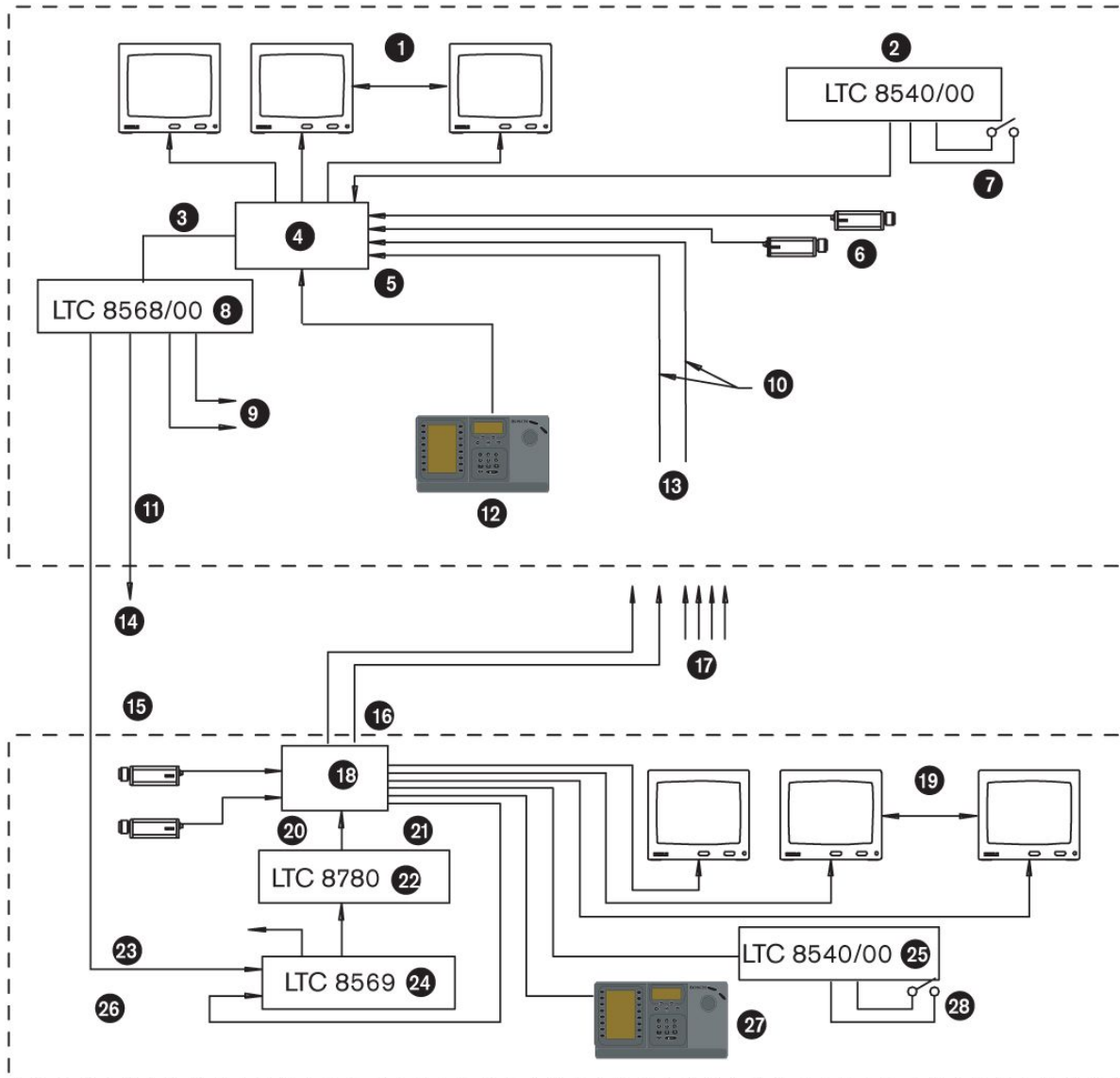

Satellite System Using LTC 5112- or LTC 5124-Series Switchers

1	Monitor Outputs	6	Local Camera Video Inputs	11	Up to 1.5 km (5000 ft) Using 1 sq mm (18 AWG) Shielded Twisted Pair (Belden 8760 or Equivalent)	16	Monitor Outputs Used As Video Trunk Lines to Main Control Site
2	Alarm Interface Unit	7	Alarm Inputs May Activate Either Local or Satellite Video on Main Control Center's Monitor	12	Allegiant Keyboard controls any local or remote camera on any local monitor (Video and PTZ)	17	Video Trunk Lines From Other Satellite Locations
3	Pan/Tilt/Zoom and Satellite Control Data	8	Signal Distribution Unit	13	Multiple Video Trunk Lines From Each Remote Satellite Location	18	Any Model Allegiant Main Bay
4	Allegiant Main CPU Bay	9	To Any Local PTZ Camera Sites	14	One Line to Each Remote Satellite System Location	19	Local Monitors
5	Inputs Used for Both Local and Trunk Lines	10	Multiple Video Coax	15	Pan/Tilt/Zoom and Satellite Control Data	20	Satellite Data Line
						21	
						22	
						23	
						24	
						25	
						26	
						27	
						28	

21 Console Port Input	25 Alarm Interface Unit
22 Data Converter Units	26 Local PTZ Control Data Line
23 To Any Local PTZ Camera Sites	27 Allegiant Keyboard controls any local or remote camera on any local monitor (Video and PTZ)
24 Code Merger Unit	28 Alarm Inputs Activate Only Local Video on Local Monitors

Technical Specifications

Capacities

Video Inputs	Standard: 64 Satellite configuration: 256
Video Outputs	8
Keyboards	8
Alarm Inputs	128
Receiver Drivers	Standard: 64 Satellite configuration: 256

Electrical

Video Bandwidth (-3 dB)	8 MHz typical
Differential Gain	3% Maximum
Differential Phase	3° Maximum
K Factor	0.5%
Signal-to-Noise-Ratio	60 dB Minimum
Crosstalk (Input Isolation)	70 dB Typical at 3.58 MHz
Feed through (Input to output isolation)	50 dB Typical at 3.58 MHz
Gain	Unity (into 75 Ohm termination)
Tilt	1% Typical

Environmental

Temperature

Operating	0°C to 50°C (32°F to 122°F)
Storage	-40°C to 60°C (-40°F to 140°F)
Altitude	3000 m (10,000 ft)
Humidity	0 to 95% relative, non-condensing
Vibration	3 g swept sine wave, 15 Hz to 2000 Hz
Shock	50 g, 11 m/s, 1/2 sine wave

LTC 8501 Series Equipment Bay

Includes LTC 8501/00 equipment rack, LTC 8511/00 microprocessor module, and LTC 8505 Series power supply.

Power Model No.	Rated Voltage	Voltage Range	Nominal Power ¹
LTC 8501/60	120 VAC, 50/60 Hz	100 to 140	192 W
LTC 8501/50	220-240 VAC, 50/60 Hz	198 to 264	192 W

1. Power at rated voltage fully loaded.

Connectors

Video Inputs	1 to 64, 1 Sync input, and 8 monitor inputs
Outputs	BNC

External Accessory Interfaces

	9-pin D-type connectors
Console	RS-232 port for external PC or control interface (default = 1200 baud)

Alarm	RS-232 port for Allegiant alarm accessory units (default = 1200 baud)
Printer	RS-232 port for system logging printer (default = 1200 baud)
SDA	TTL level, high-speed control data output (Bi-Phase) for interface to Allegiant series signal distribution units (data clock rate = 31.25 kHz)
Keyboards	Eight 6-pin RS-485 ports for Allegiant keyboard use (default = 9600 baud)

Equipment Rack

Size (W x D x H)	EIA 48 cm (19 in.) rack 483 x 356 x 178 mm (19 x 14 x 7 in.)
Weight	8.2 kg (18.2 lb)
Construction/Finish	
Top and Bottom	Steel
Front, Sides, and Back	Aluminum
Finish	Charcoal

Microprocessor Module (LTC 8511/00)

Size (D x H)	290 x 160 mm (11.5 x 6.25 in.)
Weight	0.34 kg (0.8 lb)

Power Supply

(LTC 8505/60–120 VAC, LTC 8505/50–220-240 VAC)

Size (W x D x H)	90 x 335 x 160 mm (3.46 x 13.2 x 6.25 in.)
Weight	4 kg (9 lb)
Indicators	One power On/Off, seven fuse alert, and one external sync LED

LTC 8521/00 Camera Input Module

Use up to eight (8) per equipment bay

Camera Inputs	8
Size (D x H)	290 x 160 mm (11.5 x 6.25 in.)
Weight	0.23 kg (0.5 lb)

LTC 8532/00 Monitor Output Module

Use up to four (4) per equipment bay.

Monitor Outputs	2
Size (D x H)	290 x 160 mm (11.5 x 6.25 in.)
Weight	0.27 kg (0.6 lb)

Allegiant Accessories

The LTC 8500 Series accessory products provide many optional features to the base Allegiant switching systems. Accessory products include keyboards, keyboard extension kits, receiver/driver units, switcher/followers, and code merger units. All accessory products are designed to be installer-friendly and compatible throughout the Allegiant series systems. Refer to the Allegiant Accessories datasheet for complete details.

Ordering Information

Model | Description

LTC 8501/50 Allegiant Matrix Switcher
up to 64 camera inputs, 8 monitor outputs, incl. single bay, CPU & power supply, 230 VAC, 50 Hz

LTC 8521/00 Camera Input Module
for LTC 8500, 8 camera inputs per card

LTC 8532/00 Monitor Output Module
for LTC 8500, 2 monitor outputs per card

LTC 8501/60 Allegiant Matrix Switcher
up to 64 camera inputs, 8 monitor outputs, incl. single bay, CPU & power supply, 120 VAC, 60 Hz

Accessories

LTC 8511/00 Spare CPU Module
for LTC 8501 bay

LTC 8505/50 Spare Power Supply
for LTC 8501/50 bay, 230 VAC, 50 Hz

LTC 8505/60 Spare Power Supply
for LTC 8501/60 bay, 115 V, 60 Hz

Europe, Middle East, Africa:
Bosch Security Systems B.V.
P.O. Box 80002
5600 JB Eindhoven, The Netherlands
Phone: +31 40 27 83955
Fax: +31 40 27 86668
emea.securitysystems@bosch.com
www.boschsecurity.com

Americas:
Bosch Security Systems
130 Perinton Parkway
Fairport, New York, 14450, USA
Phone: +1 800 289 0096
Fax: +1 585 223 9180
security.sales@us.bosch.com
www.boschsecurity.us

Asia-Pacific:
Bosch Security Systems Pte Ltd
38C Jalan Pemimpin
Singapore 577180
Phone: +65 6319 3450
Fax: +65 6319 3499
apr.securitysystems@bosch.com
www.boschsecurity.com

Represented by