

EX36N Corner-mount No-grip Camera

www.boschsecurity.com



BOSCH
Invented for life



- ▶ No-Grip anchor-free design for maximum safety
- ▶ Vandal-resistant housing with flush corner mount fit
- ▶ Views an entire small room, including directly beneath
- ▶ 940 nm illuminator for covert night vision to 9 m (30 ft)
- ▶ Black Diamond infrared technology

The EX36N is a vandal-resistant corner Integrated Day/Night camera featuring anchor-free No-Grip design. The EX36N has no anchor points for maximum safety in environments with at-risk individuals. The innovative design allows a perfectly flush fit into the corner of a room that protects against even the most brutal attempt to destroy, detach or disable the camera. The sharp 45° angle hides all wiring and delivers complete coverage of the entirety of a 4.5 x 4.5 m (15 x 15 ft) room, including below the camera itself. Double ¼ in LEXAN plates ensure optical clarity and are virtually unbreakable.

The EX36N incorporates mechanical filter technology for vivid daytime color and exceptional night-time imaging under infrared illumination while maintaining sharp focus under all lighting conditions. The EX36N also features proprietary CCD technology for outstanding spectral response in the near infrared for excellent active-infrared night vision.

Infrared-emitting LEDs achieve covert, effective night vision using Black Diamond technology for the most advanced level of night vision performance available today. Photocell-controlled infrared reduces energy consumption and ensures excellent imaging performance under low-light conditions. With Black Diamond technology foreground hotspots and

underexposed backgrounds are eliminated. LED intensity is adjustable for optimal performance. An optional microphone is available.

Functions

Applications

- Prisons cells
- Hospital rooms
- Psychiatric wards
- Elevators
- Storage rooms
- Interrogation rooms
- Seclusion cells
- Holding cells

Certifications and approvals

CSA C22.2 No 0-M1991	General Elec. Rqts, Part II
CSA C22.2 No 1-M94	Audio, Video and Similar Equip.
CSA C22.2 No 94-M91	Special Purpose Enclosures
UL Std No 50	Enclosures for Elec. Equipment
UL Std No 2044	Commercial CCTV Equipment
	Applicable health care facility
FCC PART 15 Class A	

Region	Certification
Europe	CE

Installation/configuration notes

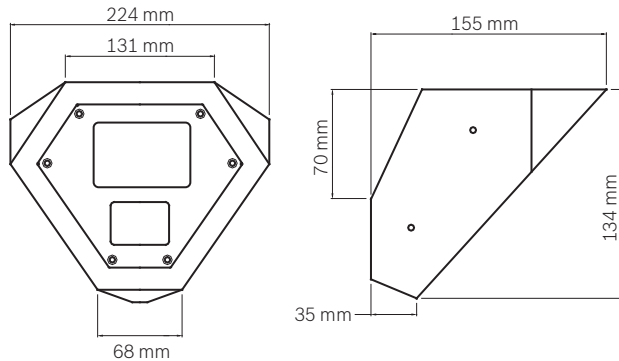

Technical specifications

Sensor	MX4 Hi-resolution day/night CCD
Resolution	540 TVL color 540 TVL monochrome
Effective Pixels	NTSC: 768 x 494 (HxV) PAL: 752 x 582 (HxV)
Sensitivity Daytime	0.02 lux with F1.4 lens
Sensitivity Night time	0.0 lux (works in total darkness)
Lens	2.5 mm
S/N Ratio	Greater than 48 dB
Filter	Mechanical dual-window IR-Pass / IR-Cut
Video Output	1 Vpp, 75 ohm
Gamma	0.45
Gain Control	AGC
Electronics Iris	1/60 to 1/100,000 (NTSC) 1/50 to 1/100,000 (PAL)
LED Type	850 nm or 940 nm, Black Diamond technology, intensity adjustable
Number of LEDs	84
Day/Night Switching	Automatic photocell-control, sensitivity adjustable
Voltage Supply	12 to 24 VAC/VDC
Power Consumption	900 mA at 12 VDC max
Voltage Regulation	Dual VRB design for enhanced electronic stability

Window	1/4 in thick LEXAN
Construction	Painted steel with flush removable front panel and tamper-resistant screws
Dimensions	224 x 134 x 155 mm (W x H x D) 8.8 x 5.3 x 6.1 in (W x H x D)
Weight	1.2 kg (2.6lb)
Temperature Range Operation	-50 °C to +50 °C (-58 °F to 122 °F)
Microphone Frequency Response	20 Hz to 10 kHz
Microphone Sensitivity	68 dB +/- 3 dB
Microphone Output	3.2 Vpp / 750 Ohm; bare leads

Ordering information

EX36MNX802W-N Corner-mount Camera

1/3 in. extended day/night, 540/540 TVL, 850 nm IR, NTSC

Order number **EX36MNX802W-N**

EX36MNX802W-P Corner-mount Camera

1/3 in. extended day/night, 540/540 TVL, 850 nm IR, PAL

Order number **EX36MNX802W-P**

EX36MNX902W-N Corner-mount Camera

1/3 in. extended day/night, 540/540 TVL, 940 nm IR, NTSC

Order number **EX36MNX902W-N**

EX36MNX902W-P Corner-mount Camera

1/3 in. extended day/night, 540/540 TVL, 940 nm IR, PAL

Order number **EX36MNX902W-P**

EX36MNX802WM-N Corner-mount No-grip Camera

1/3 in. extended day/night, 540/540TVL, 850 nm IR, NTSC, microphone

Order number **EX36MNX802WM-N**

EX36MNX802WM-P Corner-mount No-grip Camera

1/3 in. extended day/night, 540/540TVL, 850 nm IR, PAL, microphone

Order number **EX36MNX802WM-P**

EX36MNX902WM-N Corner-mount No-grip Camera

1/3 in. extended day/night, 540/540TVL, 940 nm IR, NTSC, microphone

Order number **EX36MNX902WM-N**

EX36MNX902WM-P Corner-mount No-grip Camera

1/3 in. extended day/night, 540/540TVL, 940 nm IR, PAL, microphone

Order number **EX36MNX902WM-P**

Accessories

UPA-2430-60 Power Supply

120 VAC, 60 Hz, 24 VAC, 30 VA Out

Order number **UPA-2430-60**

UPA-2420-50 Power Supply

220 VAC, 50 Hz, 24 VAC, 20 VA Out

Order number **UPA-2420-50**

PSU-124-DC050 Universal Power Supply

Universal Outdoor Power Supply, 120 to 240 VAC,
50/60 Hz In; 24 VDC, 50 W Out

Order number **PSU-124-DC050**

Represented by:

Americas:

Bosch Security Systems, Inc.
130 Perinton Parkway
Fairport, New York, 14450, USA
Phone: +1 800 289 0096
Fax: +1 585 223 9180
security.sales@us.bosch.com
www.boschsecurity.us

Europe, Middle East, Africa:

Bosch Security Systems B.V.
P.O. Box 80002
5617 BA Eindhoven, The Netherlands
Phone: + 31 40 2577 284
Fax: +31 40 2577 330
emea.securitysystems@bosch.com
www.boschsecurity.com

Asia-Pacific:

Robert Bosch (SEA) Pte Ltd, Security
Systems
11 Bishan Street 21
Singapore 573943
Phone: +65 6571 2808
Fax: +65 6571 2699
apr.securitysystems@bosch.com
www.boschsecurity.asia

China:

Bosch (Shanghai) Security Systems Ltd.
201 Building, No. 333 Fuquan Road
North IBP
Changning District, Shanghai
200335 China
Phone +86 21 22181111
Fax: +86 21 22182398
www.boschsecurity.com.cn

America Latina:

Robert Bosch Ltda Security Systems Division
Via Anhanguera, Km 98
CEP 13065-900
Campinas, Sao Paulo, Brazil
Phone: +55 19 2103 2860
Fax: +55 19 2103 2862
latam.boschsecurity@bosch.com
www.boschsecurity.com