

BOSCH

Invented for life

EX36N Corner-mount No-grip Camera



- ▶ **No-Grip anchor-free design for maximum safety**
- ▶ **Vandal-resistant housing with flush corner mount fit**
- ▶ **Views an entire small room, including directly beneath**
- ▶ **940 nm illuminator for covert night vision to 9 m (30 ft)**
- ▶ **1/3 in LXR CCD with mechanical filter technology**

The EX36N is a vandal-resistant corner Integrated Day/Night camera featuring anchor-free No-Grip design. The EX36N has no anchor points for maximum safety in environments with at-risk individuals. The innovative design allows a perfectly flush fit into the corner of a room that protects against even the most brutal attempt to destroy, detach or disable the camera. The sharp 45° angle hides all wiring and delivers complete coverage of the entirety of a 4.5 x 4.5 m (15 x 15 ft) room, including below the camera itself. Double ¼ in LEXAN plates ensure optical clarity and are virtually unbreakable.

The EX36N incorporates mechanical filter technology for vivid daytime color and exceptional night-time imaging under infrared illumination while maintaining sharp focus under all lighting conditions. The EX36N also features proprietary CCD technology for outstanding spectral response in the near infrared for excellent active-infrared night vision.

Eighty-four infrared-emitting LED's achieve covert, effective night vision. Photocell-controlled infrared reduces energy consumption and ensures excellent imaging performance under low-light conditions. LEDs intensity is adjustable for optimal performance. Available with optional microphone.

Functions

Applications

- Prisons cells
- Hospital rooms
- Psychiatric wards
- Elevators
- Storage rooms
- Interrogation rooms
- Seclusion cells
- Holding cells

Certifications and Approvals

CSA C22.2 No 0-M1991	General Elec. Rqts, Part II
CSA C22.2 No 1-M94	Audio, Video and Similar Equip.
CSA C22.2 No 94-M91	Special Purpose Enclosures
UL Std No 50	Enclosures for Elec. Equipment
UL Std No 2044	Commercial CCTV Equipment
	Applicable health care facility
FCC PART 15 Class A	

Installation/Configuration Notes

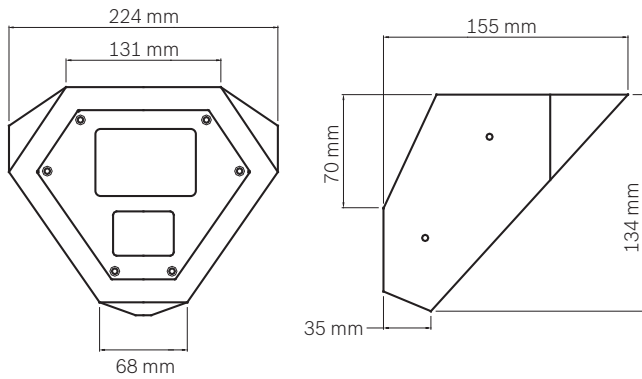

Technical Specifications

Sensor	MX4 Hi-resolution day/night CCD
Resolution	540 TVL color 540 TVL monochrome
Effective Pixels	NTSC: 768 x 494 (HxV) PAL: 752 x 582 (HxV)
Sensitivity Day-time	0.02 lux with F1.4 lens
Sensitivity Night time	0.0 lux (works in total darkness)
S/N Ratio	Greater than 48 dB
Filter	Mechanical dual-window IR-Pass / IR-Cut
Video Output	1 Vpp, 75 ohm
Gamma	0.45
Gain Control	AGC
Electronics Iris	1/60 to 1/100,000 (NTSC) 1/50 to 1/100,000 (PAL)
LED Type	850 nm or 940 nm, intensity adjustable
Number of LEDs	84
Day/Night Switching	Automatic photocell-control, sensitivity adjustable
Voltage Supply	12 to 24 VAC/VDC
Power Consumption	900 mA at 12 VDC max
Voltage Regulation	Dual VRB design for enhanced electronic stability
Window	1/4 in thick LEXAN
Construction	Painted steel with flush removable front panel and tamper-resistant screws
Dimensions	224 x 134 x 155 mm (W x H x D) 8.8 x 5.3 x 6.1 in (W x H x D)
Weight	1.2 kg (2.6lb)

Temperature Range Op- -50 °C to +50 °C (-58 °F to 122 °F)
eration

Microphone Frequency 20 Hz to 10 kHz
Response

Microphone Sensitivity 68 dB +/-3 dB

Microphone Output 3.2 Vpp / 750 Ohm; bare leads

Ordering Information

EX36MNX802W-N Corner-mount Camera 1/3 in. extended day/night, 540/540 TVL, 850 nm IR, 2.5 mm lens, NTSC	EX36MNX802W-N
EX36MNX802W-P Corner-mount Camera 1/3 in. extended day/night, 540/540 TVL, 850 nm IR, 2.5 mm lens, PAL	EX36MNX802W-P
EX36MNX804W-N Corner-mount Camera 1/3 in. extended day/night, 540/540 TVL, 850 nm IR, 3.6 mm lens, NTSC	EX36MNX804W-N
EX36MNX804W-P Corner-mount Camera 1/3 in. extended day/night, 540/540 TVL, 850 nm IR, 3.6 mm lens, PAL	EX36MNX804W-P
EX36MNX902W-N Corner-mount Camera 1/3 in. extended day/night, 540/540 TVL, 940 nm IR, 2.5 mm lens, NTSC	EX36MNX902W-N
EX36MNX902W-P Corner-mount Camera 1/3 in. extended day/night, 540/540 TVL, 940 nm IR, 2.5 mm lens, PAL	EX36MNX902W-P
EX36MNX904W-N Corner-mount Camera 1/3 in. extended day/night, 540/540 TVL, 940 nm IR, 3.6 mm lens, NTSC	EX36MNX904W-N
EX36MNX904W-P Corner-mount Camera 1/3 in. extended day/night, 540/540 TVL, 940 nm IR, 3.6 mm lens, PAL	EX36MNX904W-P
EX36MNX802WM-N Corner-mount No-grip Camera 1/3 in. extended day/night, 540/540TVL, 850 nm IR, 2.5 mm lens, NTSC, microphone	EX36MNX802WM-N
EX36MNX802WM-P Corner-mount No-grip Camera 1/3 in. extended day/night, 540/540TVL, 850 nm IR, 2.5 mm lens, PAL, microphone	EX36MNX802WM-P
EX36MNX804WM-N Corner-mount No-grip Camera 1/3 in. extended day/night, 540/540TVL, 850 nm IR, 3.6 mm lens, NTSC, microphone	EX36MNX804WM-N
EX36MNX804WM-P Corner-mount No-grip Camera 1/3 in. extended day/night, 540/540TVL, 850 nm IR, 3.6 mm lens, PAL, microphone	EX36MNX804WM-P
EX36MNX902WM-N Corner-mount No-grip Camera 1/3 in. extended day/night, 540/540TVL, 940 nm IR, 2.5 mm lens, NTSC, microphone	EX36MNX902WM-N

Ordering Information

EX36MNX902WM-P Corner-mount No-grip Camera **EX36MNX902WM-P**

1/3 in. extended day/night, 540/540TVL,
940 nm IR, 2.5 mm lens, PAL, microphone

EX36MNX904WM-N Corner-mount No-grip Camera **EX36MNX904WM-N**

1/3 in. extended day/night, 540/540TVL,
940 nm IR, 3.6 mm lens, NTSC, microphone

EX36MNX904WM-P Corner-mount No-grip Camera **EX36MNX904WM-P**

1/3 in. extended day/night, 540/540TVL,
940 nm IR, 3.6 mm lens, PAL, microphone

Accessories

PSU-230-24 Power Supply **PSU230-24**

Power Supply, 230 VAC / 24 VAC, 50 W

EXPS.008 VAC Power Supply **EXPS.008**

Power supply 120 VAC / 24 VAC 1500 mA

Americas:
Bosch Security Systems, Inc.
130 Perinton Parkway
Fairport, New York, 14450, USA
Phone: +1 800 289 0096
Fax: +1 585 223 9180
security.sales@us.bosch.com
www.boschsecurity.us

Europe, Middle East, Africa:
Bosch Security Systems B.V.
P.O. Box 80002
5600 JB Eindhoven, The Netherlands
Phone: + 31 40 2577 284
Fax: +31 40 2577 330
emea.securitysystems@bosch.com
www.boschsecurity.com

Asia-Pacific:
Robert Bosch (SEA) Pte Ltd, Security Systems
38C Jalan Pemimpin
Singapore 577180
Phone: +65 6319 3453
Fax: +65 6319 3499
apr.securitysystems@bosch.com
www.boschsecurity.com

Represented by