



## EX26LED Infrared LED Illuminator



- ▶ Low voltage infrared illuminator
- ▶ 60 high efficiency LEDs
- ▶ 840 nm (semi covert) or 940 nm (covert) LEDs
- ▶ Weatherproof housing
- ▶ Intensity adjustable infrared
- ▶ Sensitivity adjustable photocell

The EX26LED Infrared Illuminator is a versatile short to mid-range illuminator (18 m (59 ft) with 850 nm LEDs, at a 30° beam angle). It is encased in a weather-tight cast and extruded aluminum housing and is equipped with a U-bracket for instant installation.

As a 12 VDC / 24 VAC unit, it is ideal for existing CCTV installations and new CCTV projects that specify 24 hour surveillance in and around buildings in covert or semi-covert conditions.

The EX26LED is a compact, high-efficiency LED infrared illuminator that requires less than 15 W to achieve remarkable night time performance in outdoor or indoor locations.

Designed for fast and installation, the EX26LED also features photocell-sensitivity and LED intensity controls.

### Certifications and Approvals

Outdoor weather rating	CSA Type 4X
General elec. requirements, part II	CSA C22.2 No 0-M1991
Audio, video, and similar equipment	CSA C22.2 No 1-M94
Special purpose enclosures	CSA C22.2 No 94-M91
Enclosures for electrical equipment	UL Std No 50
Commercial CCTV equip	UL Std No 2044

### Functions

#### Applications

- Improving the performance of low-light cameras to effectively get the picture in night time scenes.
- General night-time surveillance
- Short to mid-range illumination
- Low voltage, 12 VDC or 24 VAC retrofits
- Indoor / outdoor infrared illumination
- Nightclubs, theatres, cabarets
- Theme park rides and dark events

**Installation/Configuration Notes**

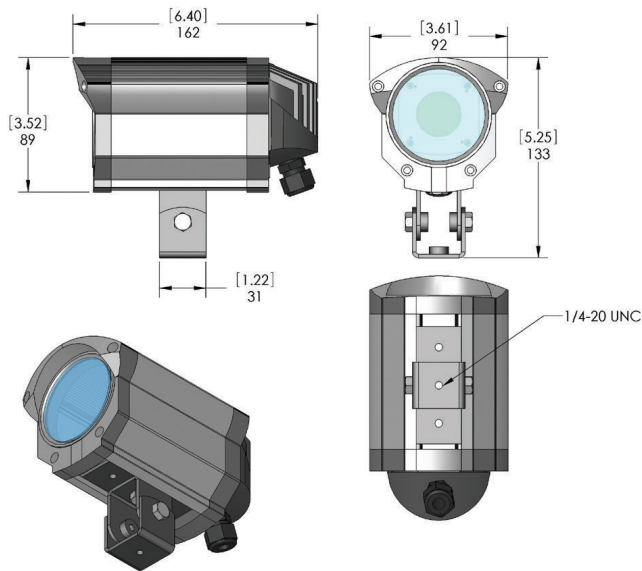

**Ordering Information**

<b>EX26LED8M Infrared LED Illuminator</b> IRw/60 LEDs, 850 nm, Med Beam 30°, 12/24 VRB, 0.7 amp, Photocell	<b>EX26LED8M</b>
<b>EX26LED9M Infrared LED Illuminator</b> IRw/60 LEDs, 940 nm, Med Beam 30°, 12/24 VRB, 0.7 amp, Photocell	<b>EX26LED9M</b>
<b>EX26LED8W Infrared LED Illuminator</b> IRw/60 LEDs, 850 nm, Wide Beam 60°, 12/24 VRB, 0.7 amp, Photocell	<b>EX26LED8W</b>
<b>EX26LED9W Infrared LED Illuminator</b> IRw/60 LEDs, 940 nm, Wide Beam 60°, 12/24 VRB, 0.7 amp, Photocell	<b>EX26LED9W</b>
<b>Accessories</b>	
<b>EXPS.008 VAC Power Supply</b> Power supply 120 VAC/ 24 VAC 1500 mA	<b>EXPS.008</b>
<b>PSU-230-24 Power Supply</b> Power Supply, 230 VAC / 24 VAC, 50 W	<b>PSU230-24</b>

**Technical Specifications**

**Electrical**

Power	
Voltage	12 VDC or 24 VAC
Power consumption	1.25 A at 12 VDC
Power supply	EXPS.008 (not included; order separately)
Number of LEDs	60
Certification	NEMA 4X / IP66
IR Intensity	Intensity adjustable
Photocell	Sensitivity adjustable
Cabling	Supplied with 2.0 m. (6.6 ft) connecting lead

**Mechanical**

Dimensions (HxWxD)	89 x 91 x 150 mm (3.5 x 3.6 x 5.9 in)
Color	Black standard (white available)
Weight	0.8 kg (1.8 lb)
Housing	Extruded and cast aluminum
U-Bracket	Aluminum top or bottom mount
Finish	Baked enamel

**Environmental**

Operation Temperature Range -50 °C to +60 °C (-58 °F to +140 °F)

**Americas:**  
Bosch Security Systems, Inc.  
130 Perinton Parkway  
Fairport, New York, 14450, USA  
Phone: +1 800 289 0096  
Fax: +1 585 223 9180  
security.sales@us.bosch.com  
www.boschsecurity.us

**Europe, Middle East, Africa:**  
Bosch Security Systems B.V.  
P.O. Box 80002  
5600 JB Eindhoven, The Netherlands  
Phone: + 31 40 2577 284  
Fax: +31 40 2577 330  
emea.securitysystems@bosch.com  
www.boschsecurity.com

**Asia-Pacific:**  
Robert Bosch (SEA) Pte Ltd, Security Systems  
38C Jalan Pemimpin  
Singapore 577180  
Phone: +65 6319 3453  
Fax: +65 6319 3499  
apr.securitysystems@bosch.com  
www.boschsecurity.com