

- **1/3" 1.3 MEGAPIXEL SONY PROGRESSIVE IMAGE SENSOR**
- **900 TVL RESOLUTION**
- **3.6mm LENS**
- **0,01 LUX (AGC On, IE Off)**
- **EXTENDED DYNAMIC RANGE**
- **VANDALPROOF**



When simplicity comes sophistication – **The Raphael series** brings the beauty of true high definition video into the world of analog camera technology.

The Raphael series embodies superb clarity and the highest visual achievement possible in video surveillance. Powered by a 1/3" 1.3 Megapixel Sony Progressive Image Sensor and our new "Raphael" DSP, these cameras produce an astonishing 900TVL resolution with unmatched color reproduction. Bring any environment to life with more pixel density than ever before, allowing users to see even the smallest details. Enhanced 3D noise reduction and an extended dynamic range ensures accurate textures and sharp images from every angle.

Each Raphael comes with an array of great features. Durable Super Flux IR LED's make them ideal for night-time monitoring, and an onboard OSD control allows users to make adjustments to get the best picture in any environment. Its aesthetically pleasing IP66 rated "Snap-Fit" housing design makes for easy installation for both indoor and outdoor applications.

OPTICAL INFORMATION

IMAGE SENSOR	1/3" 1.3 Megapixel Sony Progressive Sensor
SIGNAL SYSTEM	NTSC
CAMERA TYPE	Color Day/Night with ICR filter
RESOLUTION	900TVL
MINIMUM ILLUMINATION	0.01 Lux (AGC On, IE Off) / 0 Lux with IR On
DYNAMIC RANGE	Extended Dynamic Range
WHITE BALANCE	Auto/Manual
AGC	Auto/Fixed
BLC	Auto
ELECTRONIC SHUTTER	Auto
DIGITAL NOISE REDUCTION	3D Noise Reduction (On/Off)
OSD/CONTROL MODE	Yes, User Friendly
Mirror	Horizontal & Vertical
Privacy Masking	8 User defined Windows
Zoom	2x Zoom
Motion Detection	4 areas
VIDEO OUTPUT	BNC

LENS

LENS TYPE	3.6mm board mount IR Corrected
ANGLE OF VIEW	72 degrees
IRIS CONTROL	Auto

IR ILLUMINATION

INFRARED WAVELENGTH	10pc Super Flux LED 850nm
INFRARED LAMP IRRADIATION DISTANCE	40ft

MECHANICAL

DIMENSIONS	99mm height, 118 mm diameter (4.6 x 3.8 inch)
WEIGHT	360g (0.78ou lb)
3 AXIS DESIGN	Yes
VANDAL PROOF	Yes

ENVIRONMENTAL

OPERATING TEMPERATURE	14F to 131F (-10C to 55C)
OPERATING HUMIDITY	10% - 85% RH
ENVIRONMENTAL PROTECTION	IP66

ELECTRICAL

INPUT VOLTAGE	12VDC @ 100mA (320mA IR ON)
POWER CONSUMPTION	<5W, 100mA
RECOMMENDED POWER SUPPLY	BP0004/S

CERTIFICATIONS

CE	Yes
FCC	Yes
RoHS Compliant	Yes

General Dimensions

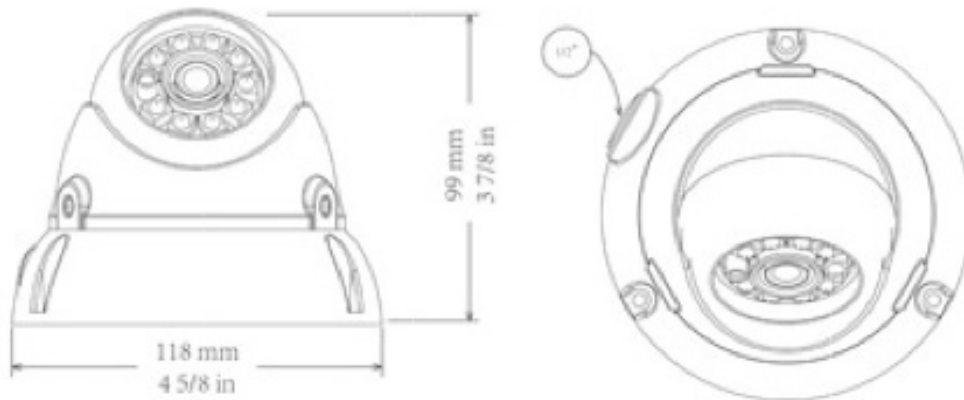

**Recommended
Power Supply**

BP0004/S