

AXIS T8646 PoE+ over Coax Blade Kit

Multi-channel migration to IP. Keep the coax.



- > No need for re-cabling, keep the coax
- > Fits Axis video encoder chassis
- > Optional PoE and PoE+ over the coax cable
- > High channel density
- > Supports Axis' network cameras

AXIS T8646 PoE+ over Coax Blade allows migration from analog to IP video surveillance systems using existing coax cabling.

Making use of current infrastructure is an important consideration when migrating from analog to digital surveillance systems. This is especially important in large-scale installations where coax cables are already present and may be very long or inaccessible. In some locations, such as hospitals or prisons, re-cabling might not even be possible.

The 6-channel hot-swappable blade fits any Axis video encoder chassis. Any combination of encoder blades and AXIS T8646 PoE+ over Coax Blades can be used simultaneously, so customers can migrate to IP at any pace they want.

To complement the solution, AXIS T8642 Ethernet over Coax Device unit PoE+ is used on the camera side. Both

the device unit and the network camera can receive power over the coax cable using AXIS T8085 500 W or AXIS T8082 1 kW + 1 kW redundant rack-mounted power supply. AXIS T8082 can also be supplemented by additional 1 kW power supplies.

A complete kit containing one AXIS T8646 PoE+ over Coax Blade and six AXIS T8642 PoE+ over Coax Device units is available.

Another advantage of AXIS T8646 in combination with an encoder chassis is that it reduces the number of switch ports needed. It also offers high channel density in a rack with up to 84 channels in 5U.



Six AXIS T8642 PoE+ over Coax Devices are included in the kit.



AXIS T8646 PoE+ over Coax Blade fits Axis video encoder chassis like AXIS Q7920 Video Encoder Chassis.

Configuration examples

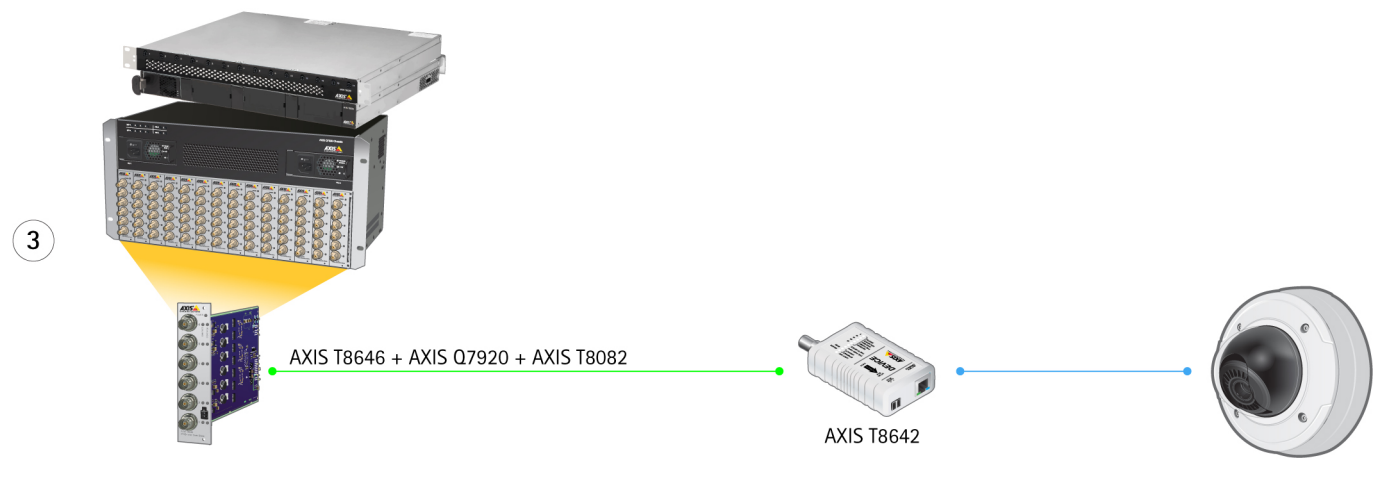
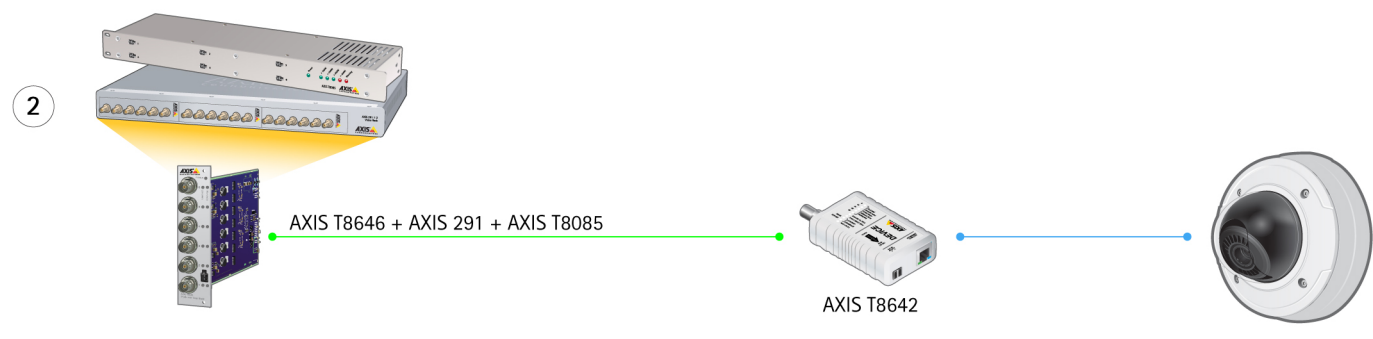
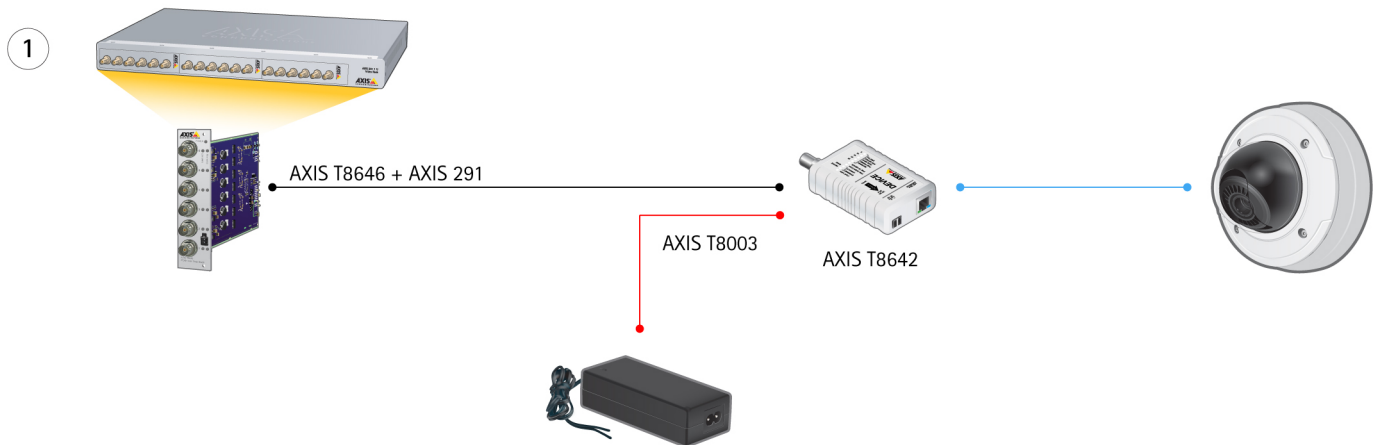

1. Front-end power option, for small-scale installations
2. Back-end power option, for mid-scale installations
3. Back-end power option, for large-scale installations
4. Data over Coax
5. Power
6. Power and Data over Ethernet
7. Power and Data over Coax

Suitable configuration depends on the number of IP cameras, calculated power consumption and length and type of existing coax cabling. Please contact us for more information.

Dimensions

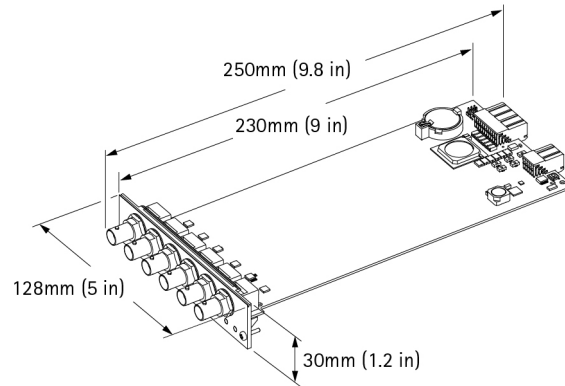

Required hardware

1. *AXIS T8642 Ethernet over Coax Device unit PoE+*

With either

2. *AXIS Q7920 Video Encoder Chassis*

Or

3. *AXIS 291 1U Video Server Rack*

1

2

3



Optional accessories

1. *AXIS T8003 PS57*

2. *AXIS T8085 PS57 500W 1U*

3. *AXIS T8082 PS57 Chassis 2kW 1U*

4. *AXIS T8081 PS57 Module 1000W for use with AXIS T8082*

1

2



3

4



Technical Specifications - AXIS T8646 PoE+ over Coax Blade Kit

Models	AXIS T8646 PoE+ over Coax Blade AXIS T8646 PoE+ over Coax Blade Kit (Contains: AXIS T8646 and six AXIS T8642 device units)	Range Table^a	280 m (492 ft) of CCS ^b RG-59
Data & power			350 m (1148 ft) of CC ^c RG-59
Data rate	Coaxial cable: 100 + 100Mbps symmetrical to full range		400 m (1312 ft) of CC ^c RG-6
Connectors	6 BNC 75 Ohm coaxial connectors DC power input for optional PoE over Coax AXIS T8642: BNC 75 Ohm coaxial connector, Shielded RJ45, EIA 568A and 568B		500 m (1640 ft) of CC ^c RG-11
Network cables	Any 75 Ohm coaxial (other impedances supported), to 500 m /1600 ft at full rate, see range table.		
Max. output power	AXIS T8646: Power over Ethernet Plus (PoE+) IEEE 802.3at Type 2 Class 4 over Coax with safe auto-detection and auto-cutout AXIS T8642: Power over Ethernet Plus (PoE+) IEEE 802.3at Type 2 Class 4 enabled to detected devices up to 25.5 W		
Input power	AXIS T8646: Powered by encoder chassis, optional DC input to enable PoE+ over coax AXIS T8642: Power over Ethernet Plus (PoE+) IEEE 802.3at Type 2 Class 4 over Coax or DC power		
Installation and management	Plug-and-play installation; Automatically detects PoE and PoE+ enabled devices and supplies in-line power Local LED management display on AXIS T8642, status LEDs on AXIS T8646		
General			
Display and indicators	Green/Amber/Red power LED Green/Amber/Red coax link/activity LED, 1 per channel Green/Amber/Red PoE+ over coax LED, 1 per channel		
Mounting	Axis' video encoder chassis only		
Environment	Indoor		
Operating conditions	0 °C to 45 °C (32 °F to 113 °F) Humidity 20-85% RH (non-condensing)		
Approvals	EN 55022 Class A, EN 55024, FCC Part 15 Subpart B Class A, ICES-003 Class A, VCCI Class A, C-tick AS/NZS CISPR 22 Class A, KCC KN22 Class A, KN24, IEC/EN/UL 60950-1		
Weight	270 g (0.6 lb)		
Warranty	AXIS T8646 Blade: Axis 3-year warranty AXIS T8646 Kit: Axis 1-year warranty For more information, see www.axis.com/warranty		

a. Full IEEE 802.3at power available over copper cored cable at full range. For CCS cable see AXIS T8640 Datasheet.

b. Copper-clad steel

c. Copper-cored

More information is available at www.axis.com