

MD-WMT2/MD-CAP

Indoor/Outdoor wall mount and 1.5" NPT mount Cap for MegaDome® Series

MD-WMT2 Wall Mount with Cap
MD-CAP 1.5" NPT Mount Cap Only



The **MD-WMT2/MD-CAP** is a high quality wall mount and cap accessory designed for the Megadome Series. Combining **MD-WMT2** and **MD-CAP** accessories with the superior imaging of an AV camera provides the perfect solution for environments requiring wall or pendant mounting configurations.

Arecont Vision Advantages:

Superior Solution for Various Environments

- Indoor or outdoor applications
- Excellent Enclosure Protection
- Heavy duty enclosure features an IP66 rating for applications in harsh environments

Easy Installation

- Easy installation and superior design, perfect for indoor or outdoor applications

Full View in All Directions

- Use the Megadome Series to ensure outstanding observation with excellent color sensitivity and high resolution

Compatibility

- Compatible with 1.5" NPT standard
- Vandal Resistant
- Die-cast aluminum, resistant to impact and salt damage

Specification sheets subject to change without notice

MD-WMT2/ MD-CAP

Model Numbers:

- MD-WMT2** Wall Mount with CAP
- MD-CAP** 1.5"NPT Mount CAP Only

Mechanical

- Housing material: Aluminum
- Color: Ivory (pantone cool gray 1c)
- Housing Height: MD-CAP : 2.57 in (65.3mm) MD-WMT2 : 4.76in (121 mm)
- Housing Diameter: 6.06 in (154.1 mm)
- Weight w/o camera: MD-CAP: 1.02 lbs (465kg) MD-WMT2 : 1.66 lbs (755g)

Environmental

- Enclosure Protection: IP66 Outdoor Protection Grade

Compatible Cameras

- MegaDome® Series

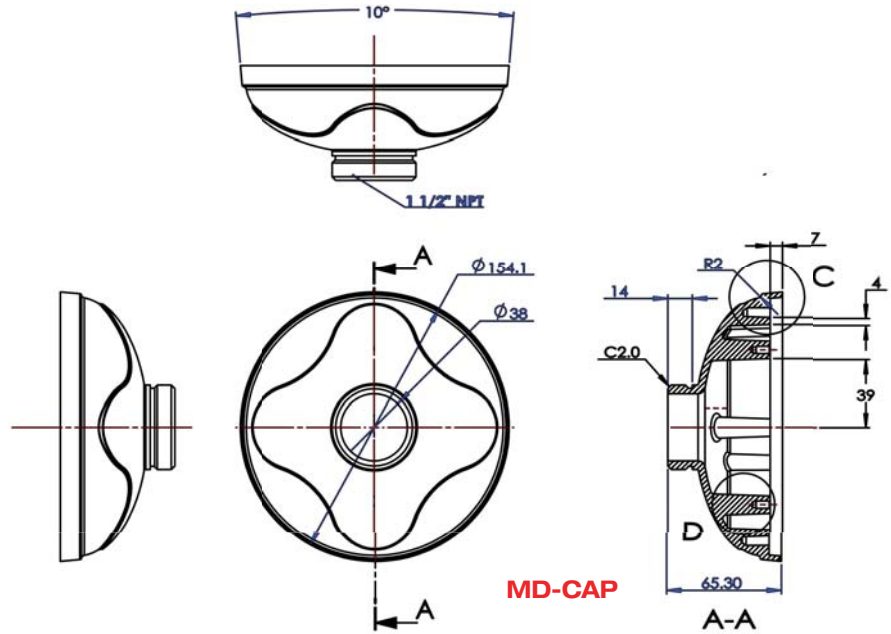

MD-CAP

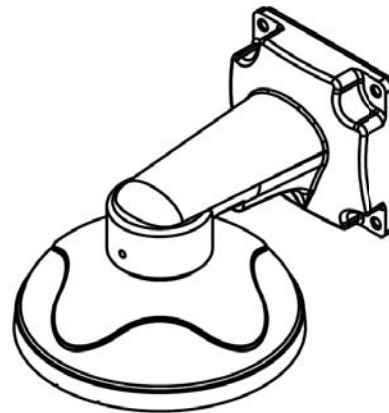
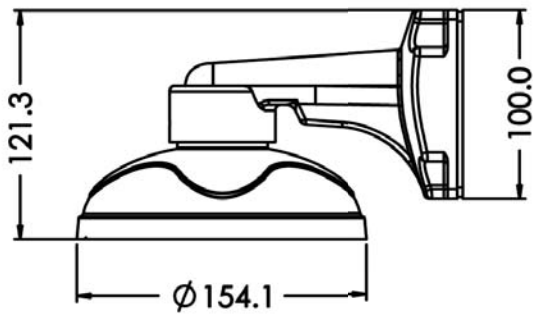

8-TAP #8-32

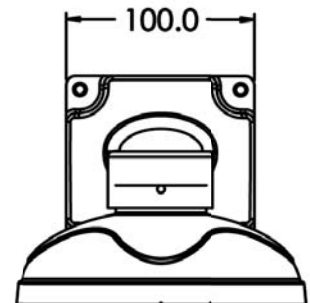
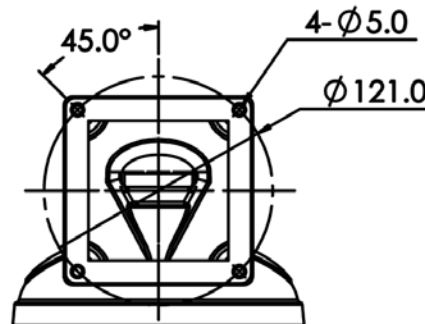
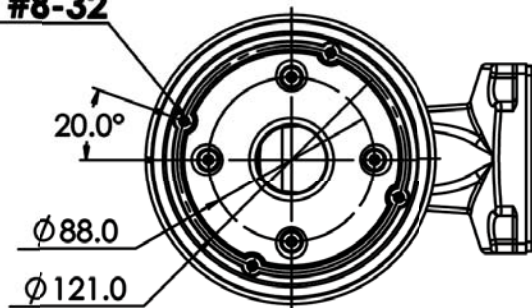

MD-WMT2