



SYMMETRY™ EN-7566HD NETWORK CAMERA

The Symmetry range of advanced network cameras provides compact design, coupled with full HD technology and H.264 video compression to meet all your video surveillance needs.

The Symmetry EN-7566HD is a compact indoor/outdoor day/night box camera with remote zoom and focus control and built in IR Illumination. Onboard support for Power over Ethernet ensures quick and easy installation coupled with increased reliability. Efficient operation allows ease of monitoring, management and maintenance, reducing the demand on time and resources.

This high performance camera comes with inbuilt advanced motion detection and optional video content analytics encompassing 3D behaviour detection including loitering, entering / exiting, appear / disappear and tailgating filters. Motion detection features include, anti- tampering, shake cancellation and real-time event tracking.

Using Symmetry network cameras in combination with market leading Video Management Software delivers a high performance seamless video solution. Cost savings are also introduced as multiple or complex sites can be monitored from one central location. The Symmetry camera range is also operational with other leading Video Management software applications.

KEY FEATURES

- High definition indoor/outdoor network camera
- Full Frame at HD1080p
- Remote Zoom/Focus Control (One Click AF)
- Video Compression: H.264
- Burnt-in Text, Video Motion Detection Support
- microSD Memory Support
- Remote Firmware Upgrade over Network
- ONVIF Support
- Embedded Video Analytics
- Built in IR Illumination

SPECIFICATIONS

Camera Module

- Image Sensor: 1/2.7" 1080p CMOS
- Effective Pixels: 1920 x 1080
- Scanning System: Progressive scanning
- AGC Control: Auto
- Minimum Illumination: Color: 0.5 lux, BW: 0 lux(IR LED On)
- Lens : 3.0 – 9.0mm Vari-Focal F1.2 Motorized Focus & Zoom
- Day & Night: IR Cut Filter Removal
- Smart Edge Enhance: Supported (Auto adjust the sharpness by Lux)
- 2D-DNR: Supported (1 ~ 16)
- White Balance: ATW / Manual / Push
- BLC: On(possible to designate zone) / Off
- IR LEDs: 34 IR LEDs
- IR Range: Internal Use : 25m, External Use : 15m
- Iris: DC Auto Iris

Video

- Compression Format: H.264, MJPEG*
- Number of Streams: Dual Stream*, Configurable
- Resolution: 1920x1080, 1280x720, 800x450, 480x270, 320x180
- FPS: 30fps@1080p (enabling analytics reduces maximum FPS / resolution)
- Motion Detection: Built-in
- Burnt-in Text: Video stream overlay text
- Output: Analog video output for installation only

Audio

- Input : 1 Output: 1*
- Compression Format: G.711

Function

- Digital Input : 1 Digital Output: 1*
- Network: 10 / 100 Base-T
- Protocol: TCP/IP, UDP/IP, HTTP, RTSP, RTP, RTCP, RTP/UDP, RTP/TCP, SNTP, mDNS, UPnP, SMTP, IGMP, DHCP, DDNS, SSL v2/v3, IEEE 802.1X, SNMP v2/v3
- SD Memory Card Slot: Built-in Micro SD slot (SD card not included)
- Recommend Class 4 and higher for HD recordings

Electrical

- Power Source: DV 12V (Adapter Included)
- Power over Ethernet: Supported (PoE, IEEE 802.3af)
- Power Consumption : 1.5A @ DC 12V (Heater On)

Environmental

- Fan / Heater: As Standard
- Operating Temperature: Operating Range
 - DC12V : -40°C ~ 50°C (-40°F ~ 122°F)
 - PoE : 0 °C ~ 50 °C (32°F ~ 122°F)
- Cold Start: DC12V : -20°C (-4°F) / PoE : 0 °C (32°F)
- Operating Humidity: Up to 85% RH, Non-condensing

*Not supported by Symmetry

Mechanical

- Material: Aluminum Die Casting
- Color: White
- Dimension: 83(W) x 82(H) x 194(D) mm (without bracket)
- Weight (Approx.): 1.5kg

Advanced Motion Detection (Included as Standard)

- High Performance: Advanced Tracking Algorithm, Low False Alarm Rate
- Easy to Use: Intuitive Web Browser Interface
- Detection Zones: Multi-segment Polygons and Lines
- On-screen Display: Real-time Display of Tracking Data and Events
- Camera Shake Cancellation: Improve the performance with cameras that are prone to shake
- Tamper Detection: Detect camera tampering

Video Content Analysis (Option)

- Detection Behavior: Direction, Stopping, Loitering, Entering, Exiting, Appear, and Disappear Filters, Tailgating* Detection
- 3D Behavior: Perspective Corrected Size and Speed Filters
- Statistics: Counting Functions and Other Statistics*
- Meta Data: Plain XML Format*

Analytics are powered by VCA Technology

Dimension: (mm)

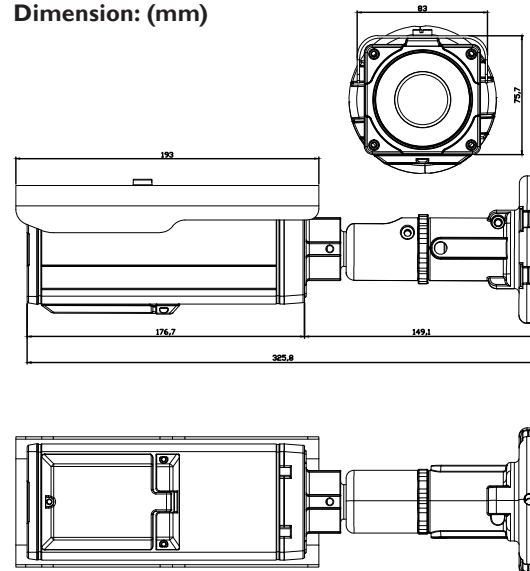

AMAG Technology

sales@amag.com

www.amag.com