

19" TFT-LCD Monitor



---

## FEATURES

---

- Displays a full, flat 19" (48cm) diagonal image
- High Resolution
- High Contrast Ratio
- High Brightness
- Wide Viewing Angle
- 2 CVBS looped, 1 SVHS looped, VGA video inputs
- VESA Wall Mount Compatible
- Tempered glass

---

## SUMMARY

---

ASTLCD17/19BB are 17"/19" TFT LCD monitors for surveillance use with two BNC inputs/outputs, one SVideo input/output and one VGA input. Their superior 3D Comb Filter, CTI and De-Interlace functions help producing sharper images and a tempered glass attached to the front panel secures better strength. System ID function enables users to control several monitors with one remote controller.

ASTLCD17/19BB use Wise-View TFT-LCDTM panel manufactured by SAMSUNG and support VESA Standard wall mount system. These products are compatible with various types of power sources and can be used in both NTSC and PAL environments.

19" TFT-LCD Monitor

**SPECIFICATIONS**

LCD Panel size	19" Diagonal AM-TFT
Resolution	1280 x 1024 @ 60Hz
Horizontal Frequency	31 KHz ~ 80 KHz
Vertical Frequency	50 Hz ~ 75 Hz
Active Display Area	376.32 x 301.056 mm
Pixel Pitch	0.294 mm(H) x 0.294 mm(V)
Brightness	300 cd/m <sup>2</sup>
Contrast ratio	700:1
Response Time	8 ms
VGA Mode	720x480@60Hz, 720x576@50Hz, 800x600@60/75Hz
Viewing Angle	75°(L)75°(R)75°(T)60°(B)
Video Input(s)	2 CH Composite, BNC, Looped 1 CH Y/C, Looped 1 CH VGA
Audio Input(s)	3 CH, 2 Chinch, 1 PC Stereo
Operating Temperature	10°C ~ +40°C
Humidity	10 ~ 80%RH
Storage Temperature	-20°C ~ +45°C
Storage Humidity	5% ~ 95%, non-condensing
Supply Voltage	12 VDC power adaptor incl.
Power Consumption	42 W
Weight	6.61 kg
Dimensions w*h*d	430 x 428 x 200 mm

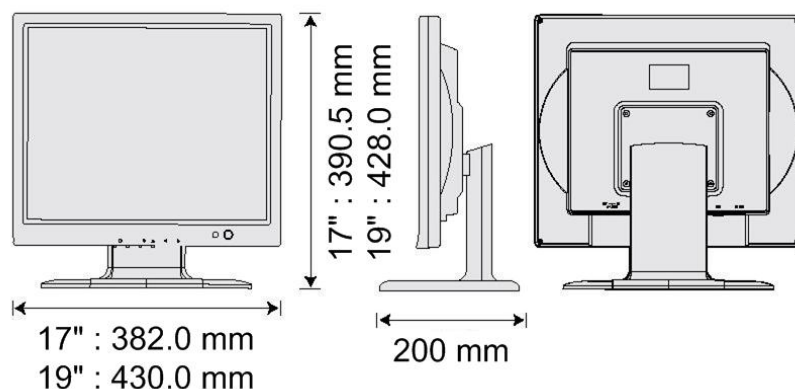
**DIMENSIONS**

Design and specifications are subject to change without notice

Status 03/2008